

The mounts should be securely packaged, accompanied by a letter including sender's name, address, day time phone number, date of purchase, date of manufacture, lot number and description of the problem or work to be performed.

Be sure to retain your packing list as proof of delivery date when making a warranty claim. If proof of delivery acceptance is not available, the warranty period shall start from the date of manufacture that is laser engraved on the mounts. Warranty is void if date of manufacture is defaced.

Wilcox Industries Corp.
 RMA#
 25 Piscataqua Drive
 Newington, NH 03801
 603-431-1331

Wilcox Industries Corp. must be contacted to assign a Return Merchandise Authorization Number (RMA) prior to return shipment. To expedite return, repair, and/or replacement of the mounts purchased under a military contract Wilcox Industries Corp. will accept any package at the address below, clearly marked:

90 days
 1 year
 Lifetime
 1 year
 1 year
 Mount Accessories and NVG Lanyards
 Mounts (Unless otherwise specified)
 Mount with Electrical Systems

Based on the Magnuson-Moss Warranty Act, Wilcox Industries Corp. offers no express warranty on its product line. However, Wilcox Industries Corp. recognizes its obligation concerning implied warranty. Wilcox Industries Corp. will not warranty any Wilcox Industries Corp. mount failure if the Wilcox Industries Corp. Mount is not utilized with the specifically-designed and matched Wilcox Industries Corp. branded Shroud. Any reseller of Wilcox Industries Corp. Shrouds and mounts are required to accept responsibility for assuring no after-market pieces are utilized in combination with Wilcox Industries Corp. mounts, which could damage the Wilcox Industries units. Use of any after-market shroud(s) specifically voids any warranty by Wilcox Industries Corp. mount(s). Liability for damages to Wilcox Industries Corp. mount(s), and the resulting requirement by the End User to repair or replace, shall fall on the reseller in the event that adherence to this stipulation has failed. All requests for warranty replacement or repairs shall come directly from the end user, following the instructions below.

Wilcox Industries Corp. mounts will be serviced or replaced in accordance with the following schedule, at no cost to the purchaser for defects in materials or workmanship. Shipment will be made via UPS ground, prepaid to any continental United States destination.

Wilcox Industries Corp. mounts will be serviced or replaced in accordance with the following schedule at no cost to the purchaser for defects in materials or workmanship. Shipment will be made via UPS ground prepaid to any continental United States destination.

THIS WARRANTY LANGUAGE SUPERSEDES ANY PURCHASE ORDER/AGREEMENT WITH ANY RESSELLER OR OEM. WILCOX INDUSTRIES CORP SPECIFICALLY DOES NOT AGREE TO ANY WARRANTY LANGUAGE OR TERMS THAT CONFLICTS WITH THE FOLLOWING:

WARRANTY STATEMENT

CARE AND MAINTENANCE

Clean the Mount by flushing away dirt with fresh water and/or wiping down the assemblies with a clean, damp cloth. If used in a salt water environment, flushing with fresh water and drying after use is recommended. If used extensively in a salt water environment, lightly lubricate stainless steel parts as needed.

Horizontal adjustment and release mechanisms that are not kept free from debris may bind, and the assembly may not lock the mount into the up or down position. Lubricate lightly as needed. Check the replaceable wear pads on the mounting interface. If worn, replace with a flat head screwdriver as illustrated.

Periodically, and after any cleaning with an air hose, apply a small amount of non-hydroscopic grease to the NVG Flip Release Bar Notch and press the NVG Release Button several times to lubricate.



Manufactured by:

WILCOX
 MODULAR BY DESIGN™

Wilcox Industries, Corp.
 25 Piscataqua Drive
 Newington, NH 03801-7816
 Phone: 603-431-1331
 Fax: 603-431-1221
 WWW.WILCOXIND.COM

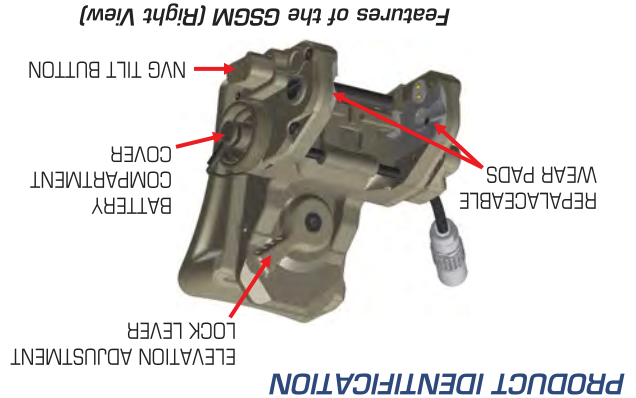

Failure to use proper NVG Attach/Detach procedures may result in damage to NVG and mount.

CAUTION

GENERAL SAFETY WARNINGS

OPERATION AND MAINTENANCE INSTRUCTIONS FOR THE WILCOX® Ground Spec Goggle Mount (GSGM) (Accommodates GPNVG, F5050 and FGS Goggles) CAGE: 004F1



© 2013-2017 Wilcox Industries Corp. All rights reserved. Printed in USA. Wilcox's line of NVG Mounting Systems is Patent Pending. Wilcox®, Mount Up!® and the Wilcox "X" Logo are federally registered trademarks of Wilcox Industries Corp. All other trademarks and registered trademarks in this manual are the property of their respective companies. Specifications and other data are subject to change without notice. **EAR Controlled: Commerce license may be required for export or re-export.**

INSTALLATION

To Attach the Wilcox Four-Hole Shroud to the Helmet



INSERT TWO LONG SCREWS THROUGH TOP HOLES FROM THE BACK; TWO SHORT SCREWS THROUGH BOTTOM HOLES. THREAD SCREWS INTO BUTTON FASTENERS ON FRONT OF MOUNT. TIGHTEN WITH SCREWDRIVER.

Step 1 - Depicted with ACH Helmet



ATTACH THE MOUNTING PLATE TO THE SHROUD.

INSERT TWO MOUNTING SCREWS INTO THE TOP HOLES OF THE MOUNTING PLATE AND SECURE WITH A SCREWDRIVER.

Step 2 - Depicted with ACH Helmet

To Attach the Interface Adapter to a Helmet Fitted with the Currently Fielded 56100634 and G35 Wilcox Three-Hole Shrouds:

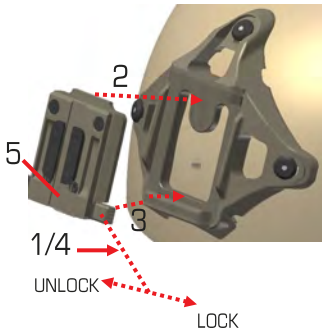

1. SLIDE THE MOUNT RELEASE LEVER TO THE RIGHT USING THE RIGHT FOREFINGER TO UNLOCK THE MOUNT RELEASE.
2. INSERT THE TOP MOUNTING GUIDE.
3. ROTATE THE MOUNT DOWNWARD UNTIL IT SEATS.
4. SLIDE THE MOUNT RELEASE LEVER TO THE LEFT USING THE RIGHT THUMB TO SECURE.
5. PRESS THE MOUNT FIRMLY AT THE BASE TO SEAT, ALLOWING THE MOUNT TO ACHIEVE ITS POSITION.

Depicted with ACH Helmet

To Attach the NVG Mount (Depicted with 4-Hole Shroud):

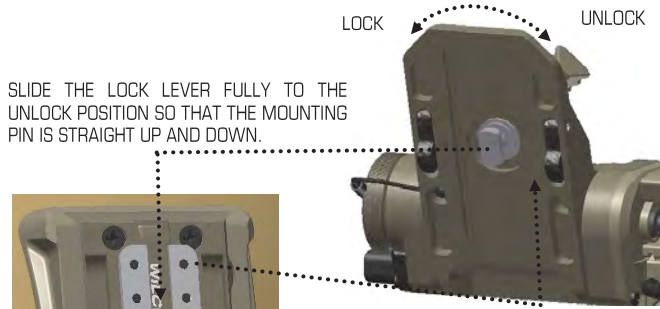

SLIDE THE LOCK LEVER FULLY TO THE UNLOCK POSITION SO THAT THE MOUNTING PIN IS STRAIGHT UP AND DOWN.

SLIDE THE MOUNT ONTO THE MOUNTING GUIDE OF THE INTERFACE PLATE AS SHOWN, ENSURING THAT THE GUIDES OF THE INTERFACE PLATE ALIGN WITH THE CHANNELS OF THE MOUNT.

ADJUST THE HEIGHT OF THE MOUNT, THEN TURN

To Replace the GSGM Battery:

UNTHREAD THE BATTERY COMPARTMENT COVER CCW AND REMOVE THE EXISTING BATTERY.

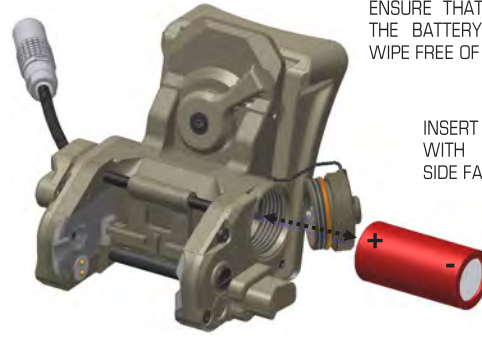

ENSURE THAT THE O-RING ON THE BATTERY CAP IS CLEAN. WIPE FREE OF ANY DEBRIS.

INSERT THE NEW BATTERY WITH THE POSITIVE "+" SIDE FACING INWARD.

REPLACE THE BATTERY CAP, ENSURING THAT IT IS HAND TIGHT.

OPERATION

To Adjust the Vertical Height of the Mount:

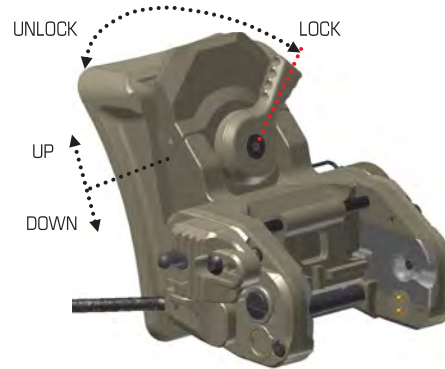

ROTATE LEVER CCW TO LOOSEN. ADJUST MOUNT HEIGHT. ROTATE LEVER CW TO LOCK.

To Pivot the Goggle:

WHILE DEPRESSING THE NVG FLIP BUTTON, PIVOT THE GOGGLE UPWARD, THEN RELEASE THE BUTTON.

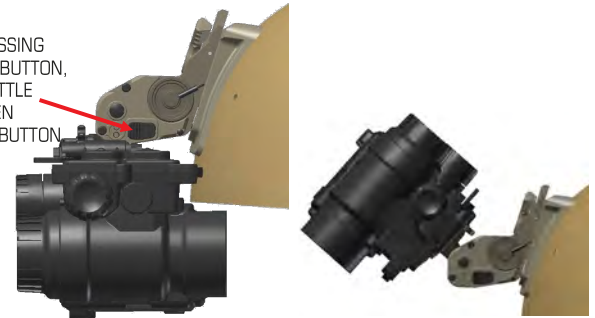

NVG Deployed

NVG Stowed

To Attach / Detach the NVG:

TO ATTACH: POSITION THE NVG TO 90° AS SHOWN, THEN INSERT THE DETENTS INTO THE MOUNTING GROOVES OF THE NVG MOUNT. PRESS UNTIL IT CLICKS. GENTLY PULL TO ENSURE THAT THE NVG IS PROPERLY MOUNTED.

TO DETACH: DEPRESS THE FLIP RELEASE BUTTON AND PIVOT THE NVG TO 90°, THEN PULL OUTWARD WHILE HOLDING THE GOGGLE WITH ONE HAND.

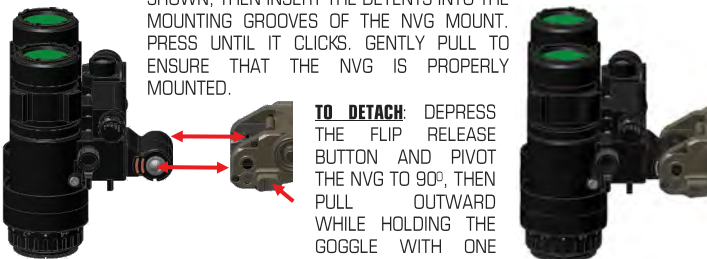

Attaching / Detaching the NVG

Attached

To Select Internal or External Power Source:

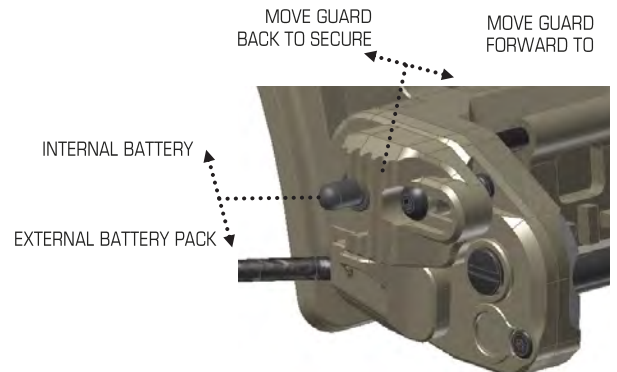

MOVE GUARD BACK TO SECURE

MOVE GUARD FORWARD TO

INTERNAL BATTERY

EXTERNAL BATTERY PACK