

**Operator's and Maintainer's Manual  
for the**

**WILCOX<sup>®</sup>**

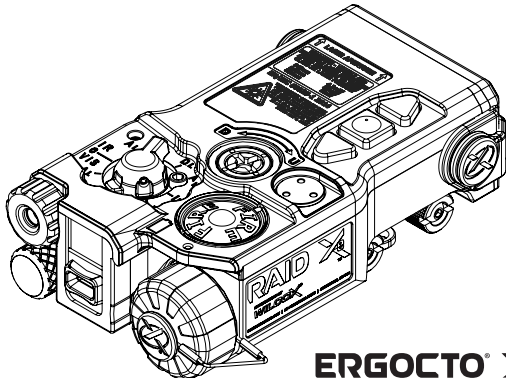
*Ruggedized Aiming / Illumination  
Device - Enhanced*

**RAID X<sup>®</sup>**  
TM

**PNs:**

**65300G07 - Low Power Red Laser  
65300G10 - High Power Red Laser  
65300G11 - High Power Green Laser**

**CAGEC: 004F1**



**ERGOCTO<sup>®</sup>** X<sup>®</sup>  
TM



## **OSHA LASER OPERATOR SAFETY REQUIREMENTS**

Inside the United States, State and Federal OSHA require the operation of Class 3B laser products to occur only under a formalized laser safety program as defined in ANSI Z136.1 Compliance with OSHA requirements are the sole responsibility of the purchaser/user.

Many countries have similar safety of use requirements. Reference the International IEC 60825 part 14, User's Guide for Laser Safety, outside the US.

## **FEDERAL RESTRICTIONS ON CLASS 3B WEAPON SIGHTS**

This product is in conformity with performance standards for laser products under 21 CFR 1040, except with respect to those characteristics authorized by Variance Number 2021-V-1262 effective February 15, 2022.

The following restrictions apply:

- The sale of this product is restricted to Federal, State, or local government law enforcement agencies only, through a direct purchase order and shall not be sold to individual personnel of these agencies or organizations.
- Immediately terminate laser emissions if optical aids (e.g., monocular, binoculars, weapon mounted optics, telescopes, etc.) are in use near the laser termination or its beam path. It is necessary and intended that the invisible beam emitted by this device be viewed by the user through night vision equipment.
- The purchasing organization must maintain a property log that lists the type and number of each device owned and the responsible party having control of these devices, and must maintain an active training program for its employees in the safe use of the laser system.
- Batteries shall be removed when the product is not intended to operate in order to prevent unauthorized use.

## **▲ WARNING ▲**

You are required to thoroughly read all instructions and product safety information in the *RAID Xe* Operator's Manual before using this product. **FAILURE TO COMPLY WITH PROPER INSTRUCTIONS COULD RESULT IN PROPERTY DAMAGE, INJURY, AND/OR DEATH.** Wilcox is not responsible for damages resulting from improper use and/or maintenance. Customers may obtain a copy of the Manual from the Wilcox website by scanning the QR code on the product.

This product contains technical data as defined in the International Traffic in Arms Regulations ITAR 22 CFR 120.10. Export of this material is restricted by the Arms Export Control Act 22 U.S.C. 2751 et seq. and may not be exported to foreign persons without prior written approval from the U.S. Department of State.

***BLACK & WHITE - NO GRAY!™***

## **SAFETY SUMMARY**

### **S1. GENERAL SAFETY INSTRUCTIONS**

WARNING and CAUTION statements have been strategically placed throughout the text to indicate operating or maintenance procedures, practices, or conditions considered essential to the protection of personnel (WARNING) or equipment and property (CAUTION). NOTES emphasize necessary and important data. WARNINGS, CAUTIONS, and NOTES appear throughout the text as applicable.

### **S2. WARNINGS, CAUTIONS, AND NOTES**

Definitions for WARNINGS, CAUTIONS, and NOTES are as follows:

#### **▲ WARNING ▲**

Highlights an operation or maintenance procedure, practice, condition, statement, etc., which, if not strictly observed, could result in injury to or death of personnel.

#### **■ CAUTION ■**

Highlights an essential operating or maintenance procedure, practice, condition, statement, etc., which, if not strictly observed, could result in damage to or destruction of equipment or loss of mission effectiveness.

#### **NOTE**

Highlights an essential operating or maintenance procedure, condition, or statement.

## **S3. SAFETY PRECAUTIONS**

### **▲ WARNING ▲**

#### *Laser Safety*

- **The RAID Xe features Class 3B laser products which emit visible and infrared laser radiation from the front end of the device. Both visible and infrared (IR) laser light can be dangerous if misused. Laser light reflected or refracted off mirrored surfaces may be equally harmful.**
  - **Never stare into a laser.**
  - **Never point lasers at someone's eyes.**
  - **Do not aim lasers at personnel or mirrored surfaces.**
  - **Never point the lasers at other persons as Class 3B lasers may cause skin irritation.**
  - **Do not look at a laser through telescopes, binoculars, scopes, image intensifiers, etc.**
  - **Direct eye exposure to a laser may cause permanent eye damage, including blindness. Special glasses for filtering laser light must be used if protection from laser radiation is required.**
- **Visible and IR laser beams are more visible when used in smoke, fog and rain, making them more easily detectable by onlookers or observers.**
- **When used in these environments, prolonged activation of the lasers should be avoided.**
- **For guidance on the proper use of lasers, refer to ANSI Z136.1, "Standard for Safe Use of Lasers", American National Standards Institute.**
- **Laser light is bright and blinding. Do not shine on aircraft or vehicles at any distance.**

▲ **WARNING** ▲

- **Laser covers are intended to be removed from the laser port when in use but NEVER physically untethered from the device. Do not operate the device if laser covers are missing, if the unit is defective, or if the laser port cover or seal is damaged.**
- **Removing the Blue Lockout Screw from the Mode Selection Switch may allow accidental exposure to high powered lasers. When high power operation is not intended, always keep the Lockout Screw in place.**
- **Make sure the weapon is CLEAR and on SAFE before installing the RAID Xe on a weapon, in accordance with the weapon's Operator's Manual, and that the RAID Xe is powered off, lens cap on prior to installation. Failure to do so can result in property damage, injury, and/or death.**
- **Operation without the Blue Lockout Screw allows the RAID Xe to function in High Power mode. High Power mode increases laser radiation which can cause damage or injury.**

*Usage Safety*

- **Wilcox strongly recommends reviewing the operational and maintenance procedures outlined in this manual prior to operating the device.**

▲ **WARNING** ▲

- Always make sure the primary battery is removed prior to mounting the *RAID Xe* to or dismounting it from the primary weapon or when performing service.
- When mounting the *RAID Xe* to a weapon, or to a new rail position, it is necessary to properly boresight the *RAID Xe* to the weapon to ensure aiming accuracy.
- When handling a weapon fitted with a *RAID Xe*, ALWAYS keep the muzzle pointed down range and clear of all personnel.
- Failure to maintain the O-ring may affect product performance.
- In the event of a detected built-in test failure, contact Wilcox Industries at 603-431-1331 and do not use this product.
- Make sure the weapon is CLEAR and on SAFE before mounting or dismounting the *RAID Xe*.

### *Battery Safety*

- Lithium batteries should be handled in the following manner:
  - If the battery compartment becomes hot to touch and you hear a hissing sound (i.e., battery venting) IMMEDIATELY turn off the equipment. Wait until battery has cooled before removing it, then replace with a fresh battery.
  - DO NOT heat, puncture, disassemble, test for capacity, short circuit, attempt to recharge, or otherwise tamper with battery.
  - Batteries have a safety vent to prevent explosion. When they are venting gas, you will smell gas, your eyes may become irritated, and/or you may hear the sound of gas escaping. When safety vents have operated, batteries are fairly safe from bursting, but will be hot and must be handled with care.

▲ **WARNING** ▲

- **DO NOT** use batteries, which look bulged or have burst. Turn these batteries in to your Property Disposal Office. Contact your Unit Safety Officer for help with bulged or burst batteries.
- **DO NOT** use water to extinguish lithium battery fire.

*Battery Safety*

- Do not store the *RAID Xe* with battery installed.
- When opening or closing the battery compartment, make sure that moisture is not allowed into the compartment.
- It is recommended that the battery be replaced and that activation procedures for the *RAID Xe* be conducted prior to operation to ensure proper operation prior to use (see Section 4.2).

*Laser Safety*

- **CAUTION** - Use of Controls or adjustments or performance of procedures other than those specified herein may result in hazardous radiation exposure.

■ **CAUTION** ■

- The **RAID Xe G10** and **G11** Models feature class 3B lasers with a maximum output power of 90 mW. Refer to Section S4 for eye safety specifications. **ALWAYS** turn off the **RAID Xe** and replace lens covers when the unit is not in use. Follow all eye and skin safety guidelines for Class 3B lasers to avoid injury to the operator or others.

■ **CAUTION** ■

- The **RAID Xe G07** Models feature class 3R lasers with a maximum output power of 32 mW. Refer to Section S4 for eye safety specifications. **ALWAYS** turn off the **RAID Xe** and replace lens covers when the unit is not in use. Follow all eye safety guidelines for Class 3R lasers to avoid injury to the operator or others.

NOTE

- When boresighting the **RAID Xe** to the target, it is recommended that only the low power Visible Laser be used.

### *Laser Safety*

- It is recommended to mount the **RAID Xe** to an integrated high quality specification rail system to optimize the designed performance of the system.
- For best results activating the laser, apply pressure to the center portion of the Fire Button Control Activation Pad.
- If the Activation Buttons on the Three Button Pressure Pad fail to operate for any reason, reseal the Three Button Pressure Pad in the Three Button Pressure Pad Connection Port of the **RAID Xe** and try again.



- The *RAID Xe* contains no serviceable internal parts and is programmable only by a Wilcox Factory Technician. Adjustments or attempted repairs to the *RAID Xe* other than those expressly described in this Operator's and Maintainer's Manual will void the warranty and could void the user's authority to operate the equipment.

**NOTE**

### *Usage Safety*

- This manual should always accompany the product and be transferred with it upon change of ownership.
- Make sure that the Mode Selection Knob is set to the "OFF" position when not in use to avoid inadvertent battery drain.
- A Laser Boresight Kit is suggested for initial zeroing to the weapon.

### *Maintenance Safety*

- Do not use harsh abrasives or chemicals such as acetone to clean the *RAID Xe*. Clean only as instructed in Section 4.1.
- Adjustments or attempted repairs to the *RAID Xe* other than those expressly described in this manual will void the warranty.

### *Battery Safety*

- Periodically inspect the Battery Compartment O-ring. If a Battery Compartment Cap O-ring becomes cut, nicked, or torn, notify unit armorer.

**S4. LASER RADIATION OUTPUT PARAMETERS****Table S4-1. RAID Xe LP (G07\*) Product Performance Specifications**

	VIS Aim (G07 Model) Red Laser		IR Aim		IR Illuminator	
	Low	High	Low	High	Low	High
Wavelength [nm]	640		850		840	
Divergence [1/e] (mrad)	<0.5		<0.5		19	
Nominal Output Power [mW]**	<0.7	3	<0.7	3.5	<0.7	25

\*With the G07 model, lasers are pulsed.

\*\*Nominal Output Power is subject to +/-10% tolerance.

**Table S4-2. RAID Xe LP (G07\*) Laser Safety Specifications**

	VIS Aim (G07 Model) Red Laser		IR Aim		IR Illuminator	
	Low	High	Low	High	Low	High
Wavelength [nm]	640		850		840	
Divergence [1/e] (mrad)	0.28		0.2		19	
Maximum Output Power [mW]**	<0.7	<4.3	<0.7	<5	<0.7	32
NSHD [m]	0	0	0	0	0	0
NOHD [m]	0	52	0	83	0	1
OD	0	0.8	0	0.9	0	1.2
NOHDe*** [m]	0	357	0	492	0	2
ODE***	0	0.7	0	0.7	0	0.2
Diode Power [mW]	30		50		100	

\*With the G07 model, lasers are pulsed.

\*\*This table is intended for laser safety guidance. Values in table exceed the set nominal values of the laser product.

\*\*\*NOHDe and ODe are calculated using standard 7x50 Binoculars as the aided viewing optics.

**Table S4-3. RAID Xe HP (G10 and G11) Product Performance Specifications**

	VIS Aim (G10 Model) Red Laser		VIS Aim (G11 Model) Green Laser		IR Aim		IR Illuminator	
	Low	High	Low	High	Low	High	Low	High
	Wavelength [nm]	660		520		850		840
Divergence [1/e] (mrad)	<0.28		0.28		0.28		12	
Nominal Output Power (mW)*	<0.7	75	<0.7	35	<0.7	30	<0.7	>50

\*Nominal Output Power is subject to +/-10% tolerance.

**Table S4-4. RAID Xe HP (G10 and G11) Laser Safety Specifications**

	VIS Aim (G10 Model) Red Laser		VIS Aim (G11 Model) Green Laser		IR Aim		IR Illuminator	
	Low	High	Low	High	Low	High	Low	High
	Wavelength [nm]	660		520		850		840
Divergence [1/e] (mrad)	0.28		0.28		0.28		14	
Maximum Output Power (mW)*	<0.7	90	<0.7	42	<0.7	36	<0.7	90
NSHD [m]	0	16	0	0	0	0	0	0
NOHD [m]	0	236	0	160	0	169	0	6
OD	0	2.0	0	1.7	0	1.7	0	2.1
NOHDe** [m]	0	1570	0	1068	0	995	0	38
ODe**	0	2.0	0	1.6	0	1.6	0	2.0
Diode Power [mW]	110		100		50		100	

\*This table is intended for laser safety guidance. Values in table exceed the set nominal values of the laser product.

\*\*NOHDe and ODe are calculated using standard 7x50 Binoculars as the aided viewing optics.

## S5. SYMBOLS



Figure S5-1. *RAID Xe* Product Symbols

## **OPERATOR'S AND MAINTAINER'S MANUAL TO SOFTWARE VERSION CROSS-REFERENCE**

The **RAID Xe** features built-in software. When utilizing any version of the **RAID Xe**, it is critical to reference the correct version of the Operator's and Maintainer's Manual for the software version that you are using. The following table provides a cross-reference for verifying the correct **RAID Xe** software revision to the correct version of the Operator's Manual.

<b><u>Manual Rev.</u></b>	<b><u>RAID Xe Software Rev.</u></b>
A-1, A-2	01.01
A-3, A-4, A-4A	2.00

**TABLE OF CONTENTS**

<b>SAFETY SUMMARY .....</b>	<b>i</b>
<b>OPERATOR'S AND MAINTAINER'S MANUAL TO SOFTWARE VERSION CROSS-REFERENCE .....</b>	<b>xi</b>
<b>TABLE OF CONTENTS.....</b>	<b>xii</b>
<b>TABLE OF TABLES .....</b>	<b>xv</b>
<b>TABLE OF ILLUSTRATIONS .....</b>	<b>xvi</b>
<b>PREFACE .....</b>	<b>xvii</b>

<b><u>Para. No.</u> <u>Title</u></b>	<b><u>Page</u></b>
--------------------------------------	--------------------

**SECTION 1: OVERVIEW**

1.1	General Safety Warnings.....	1
1.2	Model Number and Equipment Name.....	7
1.3	Manufacturer.....	7
1.4	Purpose of Equipment.....	7

**SECTION 2: INTRODUCTION**

2.1	Product Description.....	8
2.2	List of <b>RAID Xe</b> Major Components.....	9
2.3	List of <b>RAID Xe</b> Subcomponents and Ancillaries ....	10
2.4	Description of <b>RAID Xe</b> Major Components.....	14
2.5	Description of <b>RAID Xe</b> Subcomponents .....	16
2.6	Technical Data.....	23

**TABLE OF CONTENTS (CONT'D)**

<b><u>Para. No.</u></b>	<b><u>Title</u></b>	<b><u>Page</u></b>
<b>SECTION 3: OPERATION</b>		
3.1	Mounting and Dismounting the <i>RAID Xe</i> .....	25
3.2	Installing the High Power Lockout Screw on the <i>RAID Xe</i> .....	27
3.3	Attaching the <i>ERGOCTO Xe</i> Three Button Pressure Pad to the <i>RAID Xe</i> .....	28
3.4	Attaching the Rail Adapter to the Weapon Rail .....	29
3.5	Powering on the <i>RAID Xe</i> .....	30
3.6	Configuring User Function Settings.....	31
3.6.1	Setting Display Brightness.....	33
3.6.2	Setting Laser Identification Patterns.....	34
3.6.3	Selecting the Low Power Illuminator .....	35
3.6.4	Programming the Three Button Pressure Pad Buttons .....	36
3.6.5	Setting the Sleep Timer.....	38
3.6.6	Performing a Built-In Test.....	39
3.6.7	Setting Factory Defaults.....	40
3.6.8	Displaying the Maintenance Counter and Setting Weapon Type for Maintenance Counter Accuracy .....	41
3.6.9	Displaying the Event Log.....	42
3.6.10	Displaying the About Screen .....	43

**TABLE OF CONTENTS (CONT'D)**

<b>Para. No.</b>	<b>Title</b>	<b>Page</b>
3.7	Boresight Procedure (Establishing Theoretical Zero With a Laser Boresight Kit) .....	44
3.8	Pre-Operation Checklist.....	45
3.9	Operating the <i>RAID Xe</i> .....	46
<b>SECTION 4: MAINTENANCE</b>		
4.1	Care of the <i>RAID Xe</i> .....	48
4.2	Battery Replacement .....	50
4.3	Inspecting and Replacing O-Rings.....	54
4.4	Attaching and Detaching the <i>RAID Xe</i> Laser Safety Covers .....	56
4.5	Storage .....	58
4.6	Shipping .....	58
4.7	Troubleshooting.....	59
<b>APPENDIX A: WARRANTY STATEMENT</b>		
A.1	Standard Limited Warranty .....	61
A.2	Warranty Claim and Service Information .....	63
<b>APPENDIX B: ABBREVIATIONS</b>		
B.1	Abbreviations .....	64
<b>APPENDIX C: SPARE AND OPTIONAL PARTS</b>		
C.1	Spare and Optional Parts Lists .....	65



**TABLE OF TABLES**

<b><u>Table No.</u></b>	<b><u>Title</u></b>	<b><u>Page</u></b>
S4-1.	<b><i>RAID Xe</i></b> LP (G07*) Product Performance Specifications.....	viii
S4-2.	<b><i>RAID Xe</i></b> LP (G07*) Laser Safety Specifications ....	viii
S4-3.	<b><i>RAID Xe</i></b> HP (G10 and G11) Product Performance Specifications.....	ix
S4-4.	<b><i>RAID Xe</i></b> HP (G10 and G11) Laser Safety Specifications.....	ix
2.4-1.	Default Three Button Pressure Pad Functions .....	16
2.5-1	Mode Selection Options.....	17
2.5-2.	Button Operations (by Mode) .....	19
2.6-1.	Technical Data.....	23
3.6-1.	Function Menu Options.....	32
4.2-1.	<b><i>RAID Xe</i></b> Estimated Run Time (by Ambient Temperature) .....	50
4.2-2.	<b><i>RAID Xe</i></b> Estimated Remaining Battery Life (by Ambient Temperature) .....	51
4.2-3.	<b><i>RAID Xe</i></b> Key Display Indicators .....	52
4.7-1.	System Events .....	60
C-1.	Spare Parts List.....	66
C-2.	Optional Parts List.....	67

**TABLE OF ILLUSTRATIONS**

<b><u>Fig. No.</u></b>	<b><u>Title</u></b>	<b><u>Page</u></b>
S5-1.	<b><i>RAID Xe</i></b> Product Symbols.....	x
1.1-1	<b><i>RAID Xe</i></b> LP Laser Safety Label - G07 Model.....	3
1.1-2	<b><i>RAID Xe</i></b> HP Laser Safety Label - G10 Model.....	4
1.1-3	<b><i>RAID Xe</i></b> HP Laser Safety Label - G11 Model.....	5
1.1-4	<b><i>RAID Xe</i></b> Product Identification Labels .....	6
2.2-1	Major Component Identification.....	9
2.3-1	Subcomponent Identification - <b><i>RAID Xe</i></b> (1 of 2) ....	11
2.3-2	Subcomponent Identification - <b><i>RAID Xe</i></b> (2 of 2) ....	12
2.3-3	Cleaning Kit Identification - <b><i>RAID Xe</i></b> .....	13
3.1-1	Mounting the <b><i>RAID Xe</i></b> to the MIL-STD-1913 Rail (12 O'Clock Mounting Depicted) .....	26
3.2-1	Installing the High Power Lockout Screw on the <b><i>RAID Xe</i></b> .....	27
3.3-1	Attaching/Detaching the Three Button Pressure Pad to/from the <b><i>RAID Xe</i></b> .....	28
3.4-1	Attaching the Rail Adapter to the Weapon Rail .....	29
3.5-1	Display Features.....	30
3.6-1	Function Menu .....	31
4.2-1	Replacing the Battery in the <b><i>RAID Xe</i></b> .....	53
4.3-1	Inspecting and Replacing O-Ring .....	55
4.4-1.	Attaching the <b><i>RAID Xe</i></b> Laser Safety Hood .....	56
4.4-2.	Attaching the <b><i>RAID Xe</i></b> Laser Safety Visor .....	57

## PREFACE

1. SCOPE. The purpose of this Operator's and Maintainer's Manual is to assist the Operator in the operation and maintenance of the ***Ruggedized Aiming/Illumination Device - Enhanced (RAID Xe™) Power Laser Device.***

The information in this manual should not replace the experience of a trained operator. Keep this manual and all safety instructions for future use. The information must be provided to each product user.

2. REPORTING EQUIPMENT IMPROVEMENT RECOMMENDATION. Wilcox requests that all errors, omissions, and discrepancies be forwarded to: Sales Department, Wilcox Industries Corp., One Wilcox Way, Newington, NH 03801. To submit feedback by e-mail, visit **[www.wilcoxind.com/contactus](http://www.wilcoxind.com/contactus)**.

© 2017-2024 Wilcox Industries Corp. All rights reserved. Printed in USA. Patent pending. Wilcox®, ERGOCTO®, and the Wilcox "X" Logo are federally registered trademarks of Wilcox Industries Corp. Black & White - No Gray™, Our Customer's Life Depends on It!™, and Xe™ are trademarks of Wilcox Industries Corp. All other trademarks and registered trademarks in this manual are the property of their respective companies. Specifications and other data are subject to change without notice.

---

## SECTION 1

### OVERVIEW

---

#### 1.1 GENERAL SAFETY WARNINGS

The **RAID Xe** should not be used by anyone unfamiliar with its operation. This manual contains specific operating and maintenance instructions which the operator should become familiar with before actual field usage.

The Safety Warnings in this Manual are intended to point out the dangers that are common in handling this type of equipment. **Failure to observe any of these warnings may result in serious physical injury, blindness, or death.** You must familiarize yourself with the entire contents of this Operator's and Maintainer's Manual before using the **RAID Xe**. All general text, WARNINGS, CAUTIONS, and NOTES should be strictly followed.

**This manual is intended to provide you with information relevant to the operation of the RAID Xe and is not a substitute for the information contained in the Operator's and Maintainer's Manual issued by the manufacturer of any weapon to which it is attached.** It is the responsibility of the operator to read and thoroughly understand the handling and operating procedures for both the **RAID Xe** and the weapon.

## Laser Radiation Danger

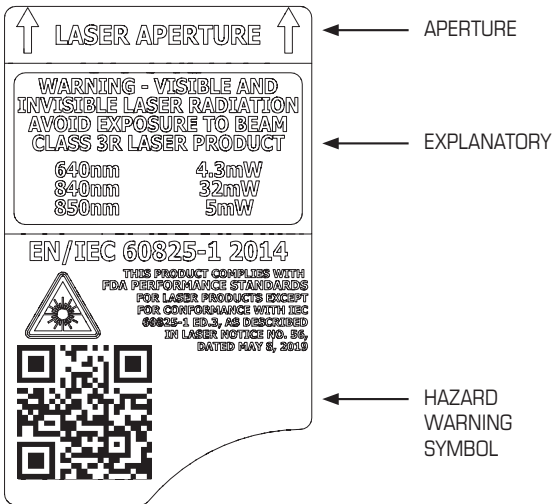
Lasers built into the **RAID Xe** emit visible and/or infrared laser radiation from the front end of the device (see Section 2.6 for technical data). Both visible and infrared laser light can be dangerous if misused. **Direct eye exposure may cause permanent eye damage, including blindness.** Laser light reflected or refracted off mirrored surfaces may be equally harmful.

- Never stare into a laser beam.
- Never point a laser beam at someone's eyes.
- Do not point a laser beam at mirrored surfaces.
- Do not look at a laser beam through telescopes, binoculars, scopes, etc.

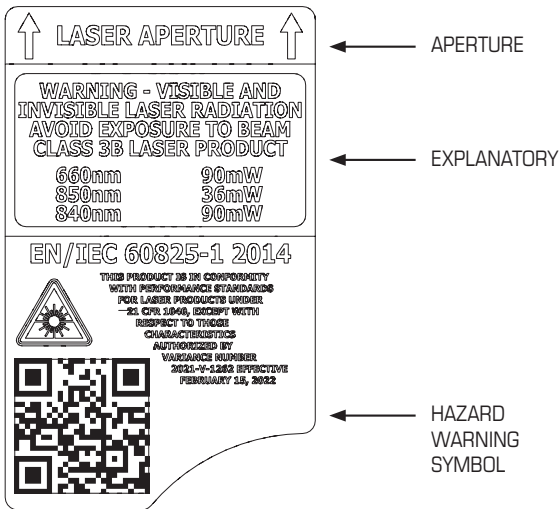
The **RAID Xe** is provided in three configurations as noted on its Product Identification Label (see Figures 1.1-1, 1.1-2, and 1.1-3). Note the laser radiation warning as displayed on the Laser Safety Label:

**WARNING - VISIBLE AND  
INVISIBLE LASER RADIATION  
AVOID EXPOSURE TO BEAM  
CLASS 3B LASER PRODUCT**

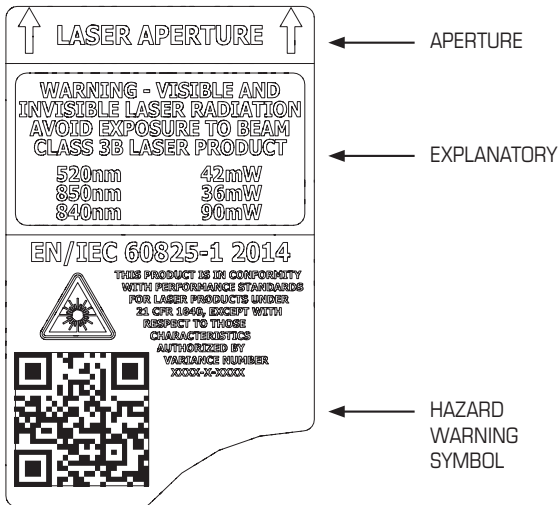
**WARNING - VISIBLE AND  
INVISIBLE LASER RADIATION  
AVOID EXPOSURE TO BEAM  
CLASS 3R LASER PRODUCT**



**Figure 1.1-1 RAID Xe LP Laser Safety Label - G07 Model**

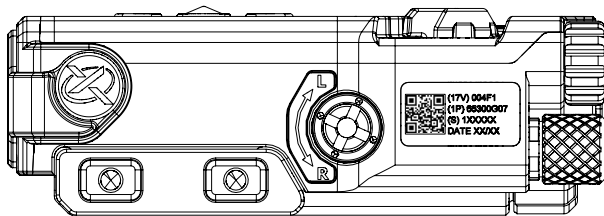


**Figure 1.1-2 RAID Xe HP Laser Safety Label - G10 Model**

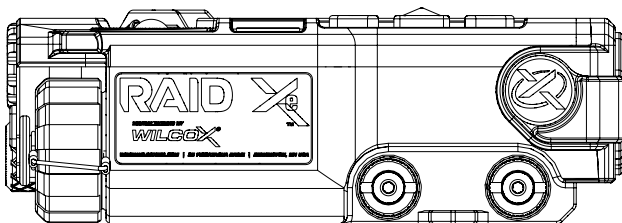


**Figure 1.1-3 RAID Xe HP Laser Safety Label - G11 Model**





**LEFT VIEW**



**RIGHT VIEW**

**RAID**  
MANUFACTURED BY  
**WILCOX<sup>®</sup>**



WWW.WILCOXIND.COM | 25 PISCATAQUA DRIVE | NEWINGTON, NH USA

**LARGER VIEWS**

**Figure 1.1-4 RAID X<sub>e</sub> Product Identification Labels**

## **First Aid**

Administer first aid in accordance with local procedures.

### **1.2 MODEL NUMBER AND EQUIPMENT NAME**

65300G07 *RAID Xe Low Power (Red Laser)*

65300G10 *RAID Xe High Power (Red Laser)*

65300G11 *RAID Xe High Power (Green Laser)*

### **1.3 MANUFACTURER**

Wilcox Industries Corp.

One Wilcox Way

Newington, NH 03801 USA

### **1.4 PURPOSE OF EQUIPMENT**

The *RAID Xe* is a multi-laser, small arms weapon mounted, pointing, aiming, and illumination system, designed to improve target acquisition and illumination for the operator when mounted to a MIL-STD-1913 or STANAG 4694 NATO rail.

---

## SECTION 2

### INTRODUCTION

---

#### 2.1 PRODUCT DESCRIPTION

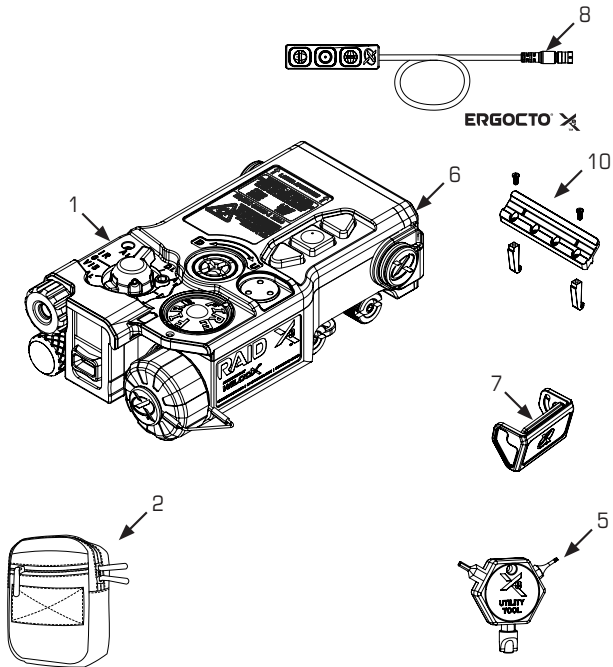
The Wilcox **RAID Xe** is a multi-laser, small arms weapon mounted, pointing, aiming, and illumination system designed to improve target acquisition and illumination for the operator when mounted to a MIL-STD-1913 or STANAG 4694 NATO rail. It features visible and Near IR (NIR) aiming lasers for target acquisition in day or night conditions. It also features both an NIR Short Range (Room) Illuminator and an NIR Long Range (Distance) Illuminator (see Table 2.6-1 for laser specifications). It features a built-in maintenance counter that provides a total round count for the system over its lifetime and attaches to the 9, 12, and 3 O'Clock positions of the primary weapon, though the 12 O'Clock position is preferred.

The **RAID Xe** provides a proven nighttime fighting capability through the use of an infrared aiming laser. It features an OLED display screen that varies in brightness by means of a built-in light sensor or through manual adjustment by the operator and is powered by a single CR123 Lithium battery (sold separately).

The **RAID Xe** is designed to allow operation with a gloved hand and to minimize snag hazard during operation with the Wilcox **ERGOCTO<sup>®</sup> Xe<sup>™</sup>** Three Button Pressure Pad or **ERGOCTO Xe** Activation Control Grip. No special tools are required for mounting or operating the **RAID Xe**.

## 2.2 LIST OF RAID X<sub>e</sub> MAJOR COMPONENTS

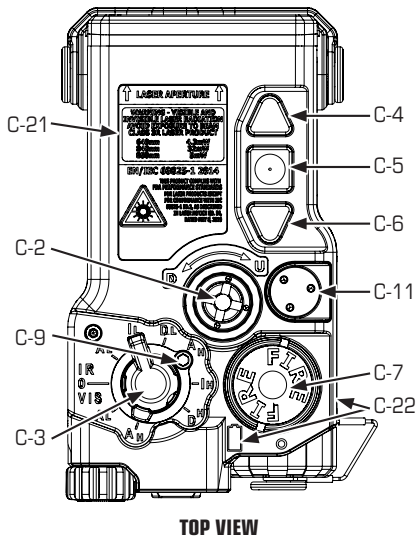
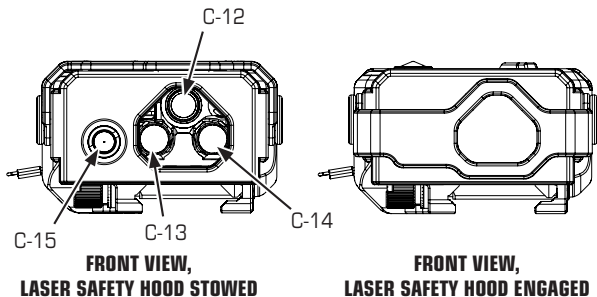
- |  |  |
|--|--|
| <ol style="list-style-type: none"> <li>1. RAID X<sub>e</sub></li> <li>2. Carrying Pouch</li> <li>3. Operator's and Maintainer's Manual (Not Depicted)</li> <li>4. Quick Reference (Not Depicted)</li> <li>5. X<sub>e</sub> Utility Tool</li> <li>6. Laser Safety Hood</li> </ol> | <ol style="list-style-type: none"> <li>7. Laser Safety Visor</li> <li>8. Three Button Pressure Pad, 12", Single Cable</li> <li>9. Three Button Pressure Pad, 12", Dual Cable (Optional, Not Depicted)</li> <li>10. Rail Adapter</li> </ol> |
|--|--|



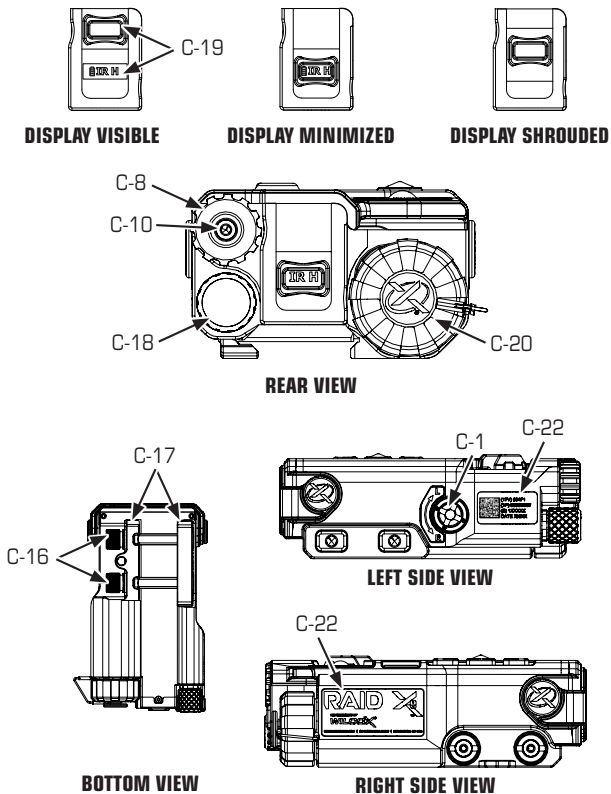
**Figure 2.2-1 Major Component Identification**

## 2.3 LIST OF *RAID Xe* SUBCOMPONENTS AND ANCILLARIES

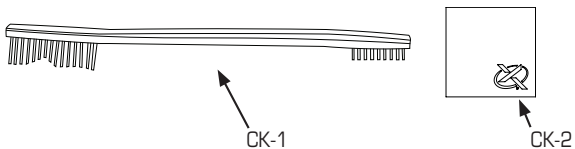
<b>COMPONENTS</b>		<b>CLEANING KIT</b>	
C-1.	Windage Adjuster	CK-1.	Cleaning Brush
C-2.	Elevation Adjuster	CK-2.	Cleaning Cloth
C-3.	Mode Selection Knob		
C-4.	Up Button		
C-5.	Enter Button		
C-6.	Down Button		
C-7.	FIRE Button		
C-8.	IR Distance Illuminator Focus Wheel		
C-9.	Blue High Power Lockout Screw		
C-10.	Blue High Power Lockout Screw Storage Port		
C-11.	Light Sensor		
C-12.	Near IR Long Range Illuminator Port (Aperture)		
C-13.	Near IR Aiming Laser (Pointer) Port (Aperture)		
C-14.	Visible Aiming Laser (Pointer) Port (Aperture)		
C-15.	Near IR Short Range Illuminator Port (Aperture)		
C-16.	Thumbnuts (2)		
C-17.	Rail Grabbers (2)		
C-18.	Three Button Pressure Pad Port and Cap		
C-19.	Adjustable Window Shroud and Display		
C-20.	Battery Compartment and Cap		
C-21.	Laser Warning Label		
C-22.	Identification Markings with 3D Barcode		



**Figure 2.3-1 Subcomponent Identification - RAID Xe (1 of 2)**



**Figure 2.3-2 Subcomponent Identification - RAID Xe (2 of 2)**



**Figure 2.3-3 Cleaning Kit Identification - RAID Xe**



## **2.4 DESCRIPTION OF RAID X<sub>e</sub> MAJOR COMPONENTS**

**1. RAID X<sub>e</sub>** The **RAID X<sub>e</sub>** features an IR Pointer Laser and IR Flood Illuminator that provide invisible targeting at close quarters and at distance. An IR Pointer Laser and IR Flood Illuminators for near and far distance provide targeting at night when used with NVGs. Boresighting is accomplished using the Visible Pointer laser and once performed all lasers will be zeroed to the weapon. One (1) commercial CR123 lithium battery (sold separately) powers the **RAID X<sub>e</sub>** (**Surefire<sup>™</sup>** brand recommended).

**2. Carrying Pouch** A Carrying Pouch is provided for stowing the **RAID X<sub>e</sub>** when not in use.

**3. Operator's and Maintainer's Manual (Not Depicted)** The **RAID X<sub>e</sub>** Operator's and Maintainer's Manual outlines the use and maintenance of the **RAID X<sub>e</sub>**. This document is available for download from the Wilcox website by scanning the QR code on the device with a cell phone.

**4. Quick Reference (Not Depicted)** The **RAID X<sub>e</sub>** Quick Reference summarizes **RAID X<sub>e</sub>** operation. The Quick Reference shall not be considered a replacement to the safety information in this Operator's and Maintainer's Manual. This document is available for download from the Wilcox website by scanning the QR code on the device with a cell phone.

**5. X<sub>e</sub> Utility Tool** The X<sub>e</sub> Utility Tool features a 5/64 Hex Key for installing and removing the blue Lockout Screw, a T5 Torx key for swapping the Laser Safety Visor with the Laser Safety Hood, and a piloted flathead screwdriver for use when torquing Thumbnuts on the Picatinny Rail to prevent slipping and marring of the Thumbnuts.

- 6. Laser Safety Hood** The **RAID Xe** is provided with a rubber Laser Safety Hood for use according to operator preference to protect the lens from damage and debris.
- 7. Laser Safety Visor** The **RAID Xe** is provided with a rigid plastic Laser Safety Visor for use according to operator preference to protect the lens from damage and debris.
- 8. Three Button Pressure Pad, 12", Single Cable** An **ERGOCTO Xe** Three Button Pressure Pad provides control of configurable laser operations (see Table 2.4-1 for default operation and section 3.6.4 for configuration). The Keypad includes a 12" single cable for connection to the **RAID Xe**.
- 9. Three Button Pressure Pad, 12", Dual Cable (Optional, Not Depicted)** An optional **ERGOCTO Xe** Three Button Pressure Pad provides control of configurable laser operations (See Table 2.41 for default operation and section 3.6.4 for configuration). The pad includes a 12" single cable for connection to the **RAID Xe** and a second cable for connection to a flashlight. For purchase information, contact Wilcox Customer Service at 603-431-1331.
- 10. Rail Adapter** An **ERGOCTO Xe** Rail Adapter is provided to secure the Three Button Pressure Pad to the side rail for ease of access to the Keypad in operation. The adapter attaches to the rail for use in any of eight (8) orientations.

**Table 2.4-1. Default Three Button Pressure Pad Functions**

	Button #1	Button #2	Button #3
Single Cable Keypad	Room Illuminator	Mirror Rotary Switch Position	Dual Low (VCSEL Illuminator + IR Aiming Laser)
Dual Cable Keypad	Flashlight*	Mirror Rotary Switch Position	Dual Low (VCSEL Illuminator + IR Aiming Laser)

\*With the Optional Dual Cable Three Button Pressure Pad, Button #1 will always control the flashlight, regardless of the configuration setting.

## 2.5 DESCRIPTION OF *RAID Xe* SUBCOMPONENTS

**C-1. Windage Adjuster** A Windage Adjuster allows for easy windage adjustment when boresighting or Zeroing of the *RAID Xe* to the weapon and maintains its setting until reset by the operator. All Lasers move together when adjusting windage. For information on adjusting Windage, refer to the Boresighting Procedure in Section 3.7.

**C-2. Elevation Adjuster** An Elevation Adjuster allows for easy elevation adjustment when boresighting or Zeroing the *RAID Xe* to the weapon and maintains its setting until reset by the operator. All Lasers move together when adjusting elevation. For information on adjusting elevation, refer to the Boresighting Procedure in Section 3.7.

**C-3. Mode Selection Knob** A Mode Selection Knob allows the operator to select the operational mode of the *RAID Xe*. When the Mode Selection Knob is set to a selected mode of operation, the display indicates the selected operational mode (see Table 2.5-1).

**C-4. Up Button** This button allows the operator to scroll up through the function menu or adjust the brightness of the current laser that is ON (see Table 2.5-2).

**C-5. Enter Button** This button allows operators to enter the submenus within the function menu OR when a laser is currently ON enter adjust mode (see Table 2.5-2).

**C-6. Down Button** This button allows the operator to scroll down through the function menu or adjust the brightness of the current laser that is ON (see Table 2.5-2).

**Table 2.5-1 Mode Selection Options**

<b>KNOB POSITION</b>	<b>OLED DISPLAY</b>	<b>LOCKOUT AVAILABLE</b>	<b>MODE/FUNCTION DESCRIPTION</b>
<b>OFF</b>		NO	<i>RAID Xe</i> Power Off
<b>AL</b>	AL I	NO	Low Power IR Aiming Laser (Pointer)
<b>IL</b>	IL I	NO	Low Power IR Short or Long Range Illuminator*
<b>DL</b>	DL I	NO	Low Power IR Aiming Laser (Pointer) and IR Short or Long Range Illuminator*
<b>AH</b>	AH I	YES	High Power IR Aiming Laser (Pointer)
<b>IH</b>	IH I	YES	High Power IR Distance Illuminator
<b>DH</b>	DH I	YES	High Power IR Aiming Laser (Pointer) and IR Long Range Illuminator
<b>AH</b>	AH V	YES	High Power Visible Aiming Laser (Pointer)
<b>AL</b>	AL V	NO	Low Power Visible Aiming Laser (Pointer)

\*Low Power IR Illuminator distance is selected within the "Illum" option on the Function Menu. NOTE: Greyed box (high power) functions are locked out with the Blue High Power Lockout Screw is in the operational position.

**C-7. FIRE Button** A Fire Button activates the selected laser as defined in Table 2.5-1. Single tap of the Fire Button emits selected laser until the button is released while double tap activates the selected laser until it is deactivated with another press of the Fire Button.

**C-8. IR Distance Illuminator Focus Wheel** Allows the operator to adjust the size of the Infrared Distance Illuminator beam aperture from a Wide Field of View (WFOV) of 110 milliradians (6 degrees) to a Near Field of View (NFOV) spot of 20 milliradians (1/2 degree). Refer to Table S4-1 for laser safety specifications.

**C-9. Blue High Power Lockout Screw** A removable Blue High Power Lockout Screw prevents the Mode Selection Knob from rotating to the High Power modes (AH, IH, and DH) when it is desired to prevent mode access. When the Lockout Screw is not installed, the knob will rotate to any mode selected by the operator and the screw can be stored in the Lockout Screw Storage Port.

**Table 2.5-2. Button Operations (by Mode)**

MODE SELECTION SWITCH POSITIONS	FIRE BUTTON OPERATION *	UP BUTTON OPERATION **	ENTER BUTTON OPERATION ***	DOWN BUTTON OPERATION **
<b>AL</b> (IR or Visible)	Low Power Aiming Laser On/Off	In Adjust Mode, Increase Aiming Laser Power One Step	Laser ON: Enter/Exit Adjust Mode Laser OFF: Toggle LP Illuminator selection	In Adjust Mode, Decrease Aiming Laser Power One Step
<b>IL</b>	Low Power Illuminator On/Off	In Adjust Mode, Increase Illuminator Power One Step	Laser ON: Enter/Exit Adjust Mode Laser OFF: Toggle LP Illuminator selection	In Adjust Mode, Decrease Illuminator Power One Step
<b>DL</b>	Both Low Power Aiming Laser and Illuminator On/Off	In Adjust Mode, Increase Illuminator or Aiming Laser Power One Step	Laser ON: Enter/Exit Adjust Mode Laser OFF: Toggle LP Illuminator selection	In Adjust Mode, Decrease Illuminator or Aiming Laser Power One Step
<b>AH</b> (IR or Visible)	High Power Aiming Laser On/Off	In Adjust Mode, Increase Aiming Laser Power One Step	Laser ON: Enter/Exit Adjust Mode Laser OFF: Toggle LP Illuminator selection	In Adjust Mode, Decrease Aiming Laser Power One Step
<b>IH</b>	High Power Illuminator On/Off	In Adjust Mode, Increase Illuminator Power One Step	Laser ON: Enter/Exit Adjust Mode Laser OFF: Toggle LP Illuminator selection	In Adjust Mode, Decrease Illuminator Power One Step
<b>DH</b>	Both High Power Aiming Laser and Illuminator On/Off	In Adjust Mode, Increase Illuminator or Aiming Laser Power One Step	Laser ON: Enter/Exit Adjust Mode Laser OFF: Toggle LP Illuminator selection	In Adjust Mode, Decrease Illuminator or Aiming Laser Power One Step
<b>[FUNCTION MENU]**</b>	Laser On/Off for the selected operational mode	Scroll up through available options	Select the Currently Highlighted Option	Scroll down through available options

\*Single tap of the Fire Button emits selected laser until the button is released while double tap activates the selected laser until it is deactivated with another press of the Fire Button.

\*\*Pressing the Up and Down Buttons simultaneously accesses the **RAID Xe** Function Menu. Note that the Function Menu is not available while laser is powered on.

\*\*\*When Laser is off and not in Function Menu, toggles between short and long Illuminator.

**C-10. Blue High Power Lockout Screw Storage Port** A small threaded storage port is located in the center of the Focus Wheel to prevent loss of the Blue High Power Lockout Screw when not in use.

**C-11. Light Sensor** A Light Sensor located on the top of the **RAID Xe** senses ambient light for determining the brightness of the Display. Covering the Light Sensor may cause the display to become too dim for use in bright conditions.

**C-12. Near IR Long Range Illuminator Port (Aperture)** The **RAID Xe** features a bright Near Infrared Flood Illumination Laser that can be used as a covert (distant) target illuminator for use in the high power modes while wearing NVGs. Refer to Sections S4 and 2.6 for laser specifications and Section 1.1 to identify the laser safety label.

**C-13. Near IR Aiming Laser (Pointer) Port (Aperture)** The **RAID Xe** features a Near Infrared Aiming Laser that can be used as a covert target designator for use while wearing NVGs. Refer to Sections S4 and 2.6 for laser specifications and Section 1.1 to identify the laser safety label.

**C-14. Visible Aiming Laser (Pointer) Port (Aperture)** The Visible Aiming Laser is used as a target designator and boresighting aid. Refer to Sections S4 and 2.6 for laser specifications and Section 1.1 to identify the laser safety label.

**C-15. Near IR Short Range Illuminator Port (Aperture)** The Near Infrared LED illuminator can be used for close quarters (room) illumination for use while in the low power modes. Refer to Sections S4 and 2.6 for illuminator specifications.

**C-16. Thumbnuts (2)** Two Thumbnuts on the integrated Rail Mount Assembly enables mounting the **RAID Xe** to the weapon using a torque specification of 30 in-lbs (see Section 3.1).

**C-17. Rail Grabbers (2)** The Rail Grabbers of the rail mount attach to the MIL-STD-1913 rail of the primary weapon for mounting the **RAID Xe**. One is affixed to the **RAID Xe** and the other floats for attachment to the rail. The **RAID Xe** is secured to the weapon by means of two Thumbnuts (see Section 3.1).

**C-18. Three Button Pressure Pad Port and Cap** The Three Button Pressure Pad Port accepts the connector of an **ERGOCTO Xe** Three Button Pressure Pad (12", Single Cable) and optional **ERGOCTO Xe** Control Activation Grip or Three Button Pressure Pad, 12", Dual Cable, and features a threaded port cap to prevent water entry. Contact Wilcox at 603-431-1331 for information on purchasing this optional device.

**C-19. Adjustable Window Shroud and Display** The **RAID Xe** features an OLED display that displays up to three rows of 6-character text information to the user. View of the display is adjustable by sliding the Window Shroud to minimize light output for nighttime operations. The shroud can slide completely out of the way for full screen display. It can also either partially or completely shroud the screen to prevent light output.

**C-20. Battery Compartment and Cap** A Battery Compartment Cap on the **RAID Xe** allows the operator to access the Battery Compartment and secures the battery in place when secured with a 1/4 turn. The internal battery compartment houses one (1) CR123 lithium battery (sold separately). Refer to Section 4.2 for battery installation instructions.



**C-21. Laser Warning Label** A Laser Warning Label identifies the laser specifications and precautions for using the **RAID Xe**.

**C-22. Identification Markings with 3D Barcode** Identifies the Product Name, Serial Number, Manufacturer Code, Manufacturing Date of the product, the battery orientation, and universal identification code containing all above mentioned items. A scannable 3D barcode indicates the Wilcox manufacturer CAGE Code (CAGEC), the Product Part, and the Serial Number of the unit when scanned by a 3D barcode reader. Tampering with this label will void the warranty.

**CK-1. Cleaning Brush** A cleaning brush is provided for removing loose dirt and debris from the mechanical components of the **RAID Xe**. DO NOT use the brush for cleaning the lenses as this may scratch the lens surface. For cleaning instructions, refer to Section 4.1.

**CK-2. Cleaning Cloth** A cleaning cloth is provided for removing any remaining residue from the lenses after they have been blown clean of dirt and dust. For cleaning instructions, refer to Section 4.1.

## 2.6 TECHNICAL DATA

**Table 2.6-1. Technical Data**

WEIGHT AND DIMENSIONS	
Operational Weight (w battery)	Less than 195 grams (6.88 oz)
Cubic Size	Less than 9 in <sup>3</sup>
LASER SPECIFICATIONS	
VIS Pointer (G07)	Visible Red Laser, <4.3 mW Max Output - HIGH Visible Red Laser, <0.7 mW Max Output - LOW 640 nm Collimated to <0.5 mrad
VIS Pointer (G10)	Visible Red Laser, 90 mW Max Output - HIGH Visible Red Laser, <0.7 mW Max Output - LOW 660 nm Collimated to <0.5 mrad
VIS Pointer (G11)	Visible Green Laser, 42 mW Max Output - HIGH Visible Green Laser, <0.7 mW Max Output - LOW 520 nm Collimated to <0.5 mrad
NIR Pointer (G07)	Infrared Laser, <5 mW Max Output - HIGH Infrared Laser, <0.7 mW Max Output - LOW 850 nm Collimated to <0.5 mrad
NIR Pointer (G10 and G11)	Infrared Laser, 36 mW Max Output - HIGH Infrared Laser, <0.7 mW Max Output - LOW 850 nm Collimated to <0.5 mrad
NIR Near Fixed Illuminator LED (Low Power IR Modes)	LED, 45 mW Max Output 870 nm 40 Degree FOV
NIR Distance Variable Illuminator (High Power IR Modes) (G07)	Infrared Laser, 32 mW Max Output - HIGH Infrared Laser, <0.7 mW Max Output - LOW 840 nm Variable Collimation >19 mrad (1/e)
NIR Distance Variable Illuminator (High Power IR Modes) (G10 and G11)	Infrared Laser, 90 mW Max Output - HIGH Infrared Laser, <0.7 mW Max Output - LOW 840 nm Variable Collimation 12 to 74 mrad (1/e)

**TEMPERATURE SPECIFICATIONS**

Operating Temperature Range	-4° F ( -20° C) to 140° F (60° C)
-----------------------------	-----------------------------------

Storage Temperature Range	-40° F ( -40° C) to 160° F (71° C)
---------------------------	------------------------------------

**ADDITIONAL SPECIFICATIONS**

Power Source	One (1) CR123 Lithium Battery (sold separately); Wilcox recommends the Surefire Lithium CR123 battery.
--------------	--

Display	72x 40 Pixel OLED
---------	-------------------

Color	Black or Coyote Brown Matte Finish
-------	------------------------------------

Low Pressure Altitude	25,000 Feet Above Sea Level
-----------------------	-----------------------------

Water Resistance	Waterproof to 1 Meter for 60 Minutes
------------------	--------------------------------------

---

## SECTION 3

### OPERATION

---

#### 3.1 MOUNTING AND DISMOUNTING THE *RAID Xe*

The *RAID Xe* features a built-in Rail Mount that allows the *RAID Xe* to attach to the MIL-STD-1913 rail of the primary weapon by means of two (2) Thumbnuts and a rail grabber. It mounts to the 9, 12, and 3 O'Clock positions of the primary weapon (12 O'Clock is preferred).

#### ▲ **WARNING** ▲

**Make sure the weapon is CLEAR and on SAFE before installing the *RAID Xe* on a weapon, in accordance with the weapon's Operator's Manual, the *RAID Xe* is powered off, and the lens cap is on prior to installation. Failure to do so can result in property damage, injury, and/or death.**

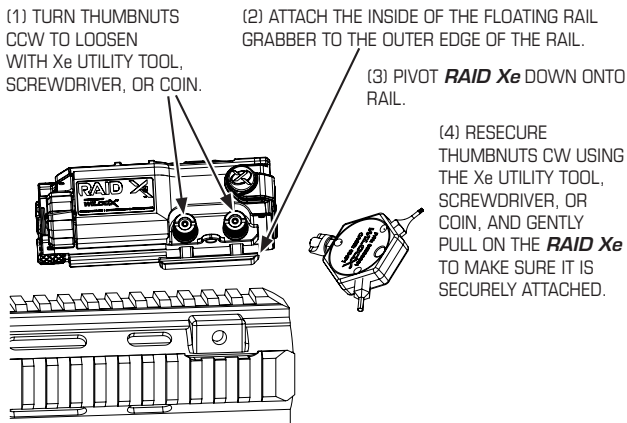
#### **To Mount the *RAID Xe* to the Primary Weapon:**

- Step 1.)** Fully unthread the two Thumbnuts CCW to loosen the rail grabber.
- Step 2.)** Attach the *RAID Xe* floating rail to the MIL-STD-1913 rail of the weapon.
- Step 3.)** Pivot the *RAID Xe* downward so that it sits flat on the weapon rail and the opposite rail grabber is positioned to engage.

- Step 4.)** Turn the Thumbnuts CW using the Xe Utility Tool, screwdriver, or coin, alternating between the Thumbnuts for even distribution. 30 in-lb is recommended. Attempt to remove the **RAID Xe** from the rail by pulling to make sure it is securely attached. If not properly attached, retighten.

### **To Dismount the RAID Xe from the Primary Weapon:**

Carefully grasp the **RAID Xe** then unthread the Thumbnuts CCW to allow the locking plate to slide, using caution not to release the Thumbnuts from the screw. Pivot the **RAID Xe** away from the rail.



**Figure 3.1-1 Mounting the RAID Xe to the MIL-STD-1913 Rail (12 O'Clock Mounting Depicted)**

### 3.2 INSTALLING THE HIGH POWER LOCKOUT SCREW ON THE *RAID Xe*

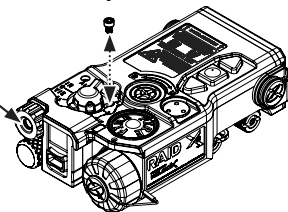
The blue High Power Lockout Screw prevents accidental operation of High Power Lasers when Low Power operation is intended when positioned in the Mode Selection Switch. To prevent accidental discharge of high power lasers, install the blue High Power Lockout Screw.

(1) PLACE THE MODE SELECTION SWITCH IN THE "OFF" POSITION.

WHEN NOT IN USE, THREAD SCREW IN PLACE HERE TO PREVENT LOSS OF THE SCREW.



(2) INSTALL THE BLUE HIGH POWER LOCKOUT SCREW USING THE XE UTILITY TOOL OR A 5/64" HEX KEY.



**Figure 3.2-1** Installing the High Power Lockout Screw on the *RAID Xe*

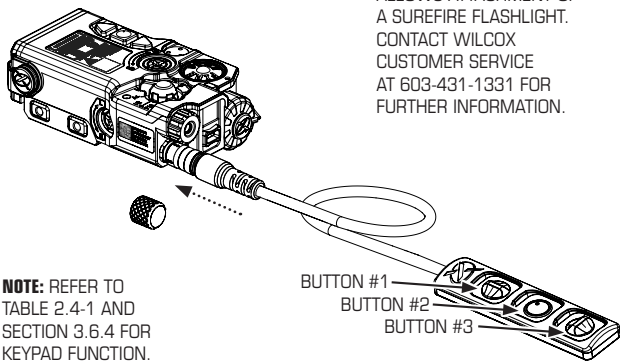
### 3.3 ATTACHING THE *ERGOCTO Xe* THREE BUTTON PRESSURE PAD TO THE *RAID Xe*

An *ERGOCTO Xe* Three Button Pressure Pad and optional Control Activation Grip are available for the *RAID Xe* that allows operation of the selected lasers. It attaches to the Three Button Pressure Pad Port on the *RAID Xe* when in use. For purchase information, contact Wilcox Customer Service at 603-431-1331.

**TO ATTACH:** UNTHREAD THE PORT CAP CCW AND REMOVE. INSERT THE THREE BUTTON PRESSURE PAD CONNECTOR INTO THE PRESSURE PAD PORT AND PUSH UNTIL IT CLICKS.

**TO DETACH:** GRASP THE HEAD OF THE CONNECTOR AND PULL OUT. DO NOT PULL ON THE WIRES. REINSTALL THE PORT CAP.

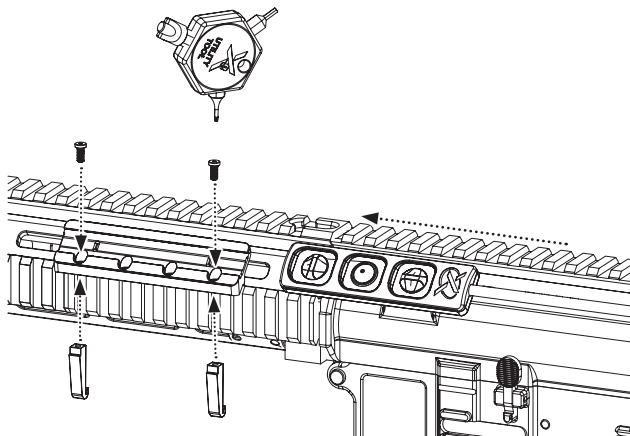
**NOTE:** THE DUAL CABLE OPTION ADDITIONALLY ALLOWS ATTACHMENT OF A SUREFIRE FLASHLIGHT. CONTACT WILCOX CUSTOMER SERVICE AT 603-431-1331 FOR FURTHER INFORMATION.



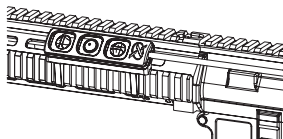
**Figure 3.3-1 Attaching/Detaching the Three Button Pressure Pad to/from the *RAID Xe***

### 3.4 ATTACHING THE RAIL ADAPTER TO THE WEAPON RAIL

A Rail Adapter is provided to secure the Three Button Pressure Pad to the side rail for ease of access in operation. The adapter attaches to the rail for use in any of 8 orientations on the rail.



**TO ATTACH:** THREAD SCREWS THROUGH THE ADAPTER INTO THE GRAB ARMS USING THE Xe UTILITY TOOL OR .050" HEX KEY, THEN SLIDE KEYPAD ONTO ADAPTER INTERFACE.



**ATTACHED**

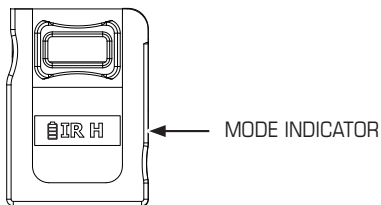
**Figure 3.4-1 Attaching the Rail Adapter to the Weapon Rail**



## 3.5 POWERING ON THE *RAID Xe*

### To Power On the *RAID Xe*:

- Step 1.)** Make sure the *RAID Xe* is securely mounted.
- Step 2.)** Turn the Mode Selection Knob to select the desired mode of operation. When the power is on in any mode, the Display illuminates. The active mode of the laser appears on the display (see Figure 3.5-1). If the *RAID Xe* display indicates that a low battery condition exists when powered on, replace the battery as described in Section 4.2.

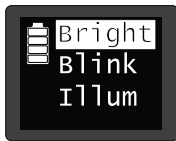


**Figure 3.5-1** Display Features

### 3.6 CONFIGURING USER FUNCTION SETTINGS

The **RAID Xe** Function Menu allows the operator to display and/or configure a variety of **RAID Xe** attributes (see Table 3.6-1). Push the Up and Down buttons simultaneously to enter or exit the Function Menu.

The “**Bright**” option allows the operator to set the display brightness to automatically dim and brighten in accordance with ambient light or to a manually set value. To quickly restore the **RAID Xe** to automatic brightness, push and hold the Up and Down Buttons while powering on the system.



**Figure 3.6-1** Function Menu

**Table 3.6-1. Function Menu Options**

<b>FUNCTION</b>	<b>DESCRIPTION</b>	<b>VALUES</b>	<b>DEFAULT</b>
<b>Bright</b>	Adjust Display Brightness	Auto, Dim 4, Dim 3, Dim 2, Dim 1, Brite1, Brite2, Brite3, Brite4	Auto
<b>Blink</b>	Set the Laser ID Blink Pattern	ID:OFF, ID: 1, ID: 2, ID: 3, ID: 4, ID: 5, ID: 6	ID:OFF
<b>Illum</b>	Selecting the Low Power Illuminator	Short, Long	Short
<b>Remote</b>	Select Optional Remote Button Function	Button 1, Button 2, Button 3, Exit	1: ILrI 2: Fire 3: DH I
<b>ScrnSv</b>	Adjust Inactivity Timeout	Off, 1 M, 3 M, 5 M, 10 M	5 M
<b>Test</b>	Perform a Built In Test		—
<b>Deflt</b>	Set Factory Defaults	Reset, NO Rst	NO Rst
<b>Maint</b>	Display or Configure the Maintenance Counter		
<b>Maint &gt; Config</b>	Set the Weapon Mechanism Type	GasImp, Piston	GasImp
<b>Events</b>	Display the Event Log	—	—
<b>About</b>	Display Version Information and Battery %	—	—

### 3.6.1 Setting Display Brightness

#### To Set Display Brightness:

**Step 1.)** Push the Up and Down Buttons simultaneously to access the Function Menu. The first highlighted function menu option (i.e., "**Bright**") appears on the display. Push the Enter Button to enter the "Bright" Menu.

**Step 2.)** Push the Up or Down Button until the desired option is highlighted, then push the Enter Button to select.

#### OPTION

#### DESCRIPTION

**Auto (DEFAULT)**

Dim 3 to Brite4, Based on Light Sensor Input

**Dim 4\***

Dimmest

**Dim 3**

...

**Dim 2**

...

**Dim 1**

...

**Brite1**

...

**Brite2**

...

**Brite3**

...

**Brite4**

Brightest

\*The "**Dim 4**" (lowest brightness option) is not available from Auto mode. If this is required for NVG usage, use the manual setting to acquire this brightness level.

**Step 3.)** Push the Up and Down Buttons simultaneously to exit this Function Menu.

### 3.6.2 Setting Laser Identification Patterns

The **RAID Xe** provides a built-in “Blink” function that allows the operator to set a custom blink identification pattern for the **RAID Xe** pointer lasers.

#### **To Set the Laser ID Blink Pattern:**

- Step 1.)** With lasers turned off, push the Up and Down Buttons simultaneously to access the Function Menu.
- Step 2.)** Push the Up or Down Button until “**Blink**” is highlighted, then press the Enter Button to select.
- Step 3.)** Push the Up or Down Button until the desired option is highlighted, then push the Enter Button to Select.

<b><u>OPTION</u></b>	<b><u>DESCRIPTION</u></b>
<b>ID:OFF (DEFAULT)</b>	No Blinking
<b>ID: 1</b>	Fast Blink Rate
<b>ID: 2</b>	Medium Fast Blink Rate
<b>ID: 3</b>	Medium Slow Blink Rate
<b>ID: 4</b>	Slow Blink Rate
<b>ID: 5</b>	Fast with Double Blink
<b>ID: 6</b>	Slow with Double Blink

- Step 4.)** Push the Up and Down Buttons simultaneously to exit this Function Menu.

### 3.6.3 Selecting the Low Power Illuminator

The “Illum” function allows the operator to select between the “Short” Range Illuminator or “Long” Range Illuminator when operating in Low Power illuminator modes.

#### **To Select the Low Power Illuminator:**

- Step 1.)** With lasers turned off, push the Up and Down Buttons simultaneously to access the Function Menu.
- Step 2.)** Push the Up or Down Button until “**Illum**” is highlighted, then push the Enter Button to select.
- Step 3.)** Push the Up or Down Button until the desired option is highlighted, then push the Enter Button to Select.

#### **OPTION**

#### **DESCRIPTION**

#### **Short (DEFAULT)**

Low Power, Short Range Illuminator

#### **Long**

Low Power, Long Range Focusable Illuminator

- Step 4.)** Push the Up and Down Buttons simultaneously to exit this Function Menu.

### **3.6.4 Programming the Three Button Pressure Pad Buttons**

The "Remote" function allows the operator to program the function of each button of the *ERGOCTO Xe* Three Button Pressure Pad (see Table 2.4.1 for default operation).

#### **To Program the Three Button Pressure Pad Buttons:**

- Step 1.)** Push the Up and Down Buttons simultaneously to access the Function Menu.
- Step 2.)** Push the Up or Down Button until "**Remote**" is highlighted, then push the Enter Button to select.
- Step 3.)** Push the Up or Down Button until the desired Button is highlighted or Exit to return to the Function Menu, then push the Enter button to select.

**Step 4.)** Push the Up or Down Button until the desired option is highlighted, then push the Enter button to select.

<b><u>OPTION</u></b>	<b><u>DESCRIPTION</u></b>
<b>AL V</b>	Low Power Visible Aiming Laser
<b>AL I</b>	Low Power IR Aiming Laser
<b>IL I</b>	Low Power IR Illuminator
<b>ILrL</b>	Low Power IR LED Illuminator
<b>DL I</b>	Dual Low Infrared Laser and Illuminator
<b>AH V*</b>	High Power Visible Aiming Laser
<b>AH I*</b>	High Power IR Aiming Laser
<b>IH I*</b>	High Power IR Illuminator
<b>DH I*</b>	Dual High Power IR Laser and Illuminator
<b>Fire</b>	Activates current laser selected by the switch position

\*In Low Power switch positions, High Power laser configurations will be limited to the maximum Low Power setting.



**Step 5.)** Push the Up and Down Buttons simultaneously to exit the Function Menu.

### 3.6.5 Setting the Sleep Timer

The "ScrnSv" function allows the operator to set the amount of inactive time before the **RAID Xe** goes into a power saving Sleep Mode. When the **RAID Xe** is in Sleep Mode, the display will be powered off and only essential functions will be running. The inactivity timer begins when lasers are not on and no buttons are pressed. Pushing any button, changing the mode selection or a detected weapon fire will wake the **RAID Xe**.

#### To Set the Sleep Timer:

**Step 1.)** Push the Up and Down Buttons simultaneously to access the Function Menu.

**Step 2.)** Push the Up or Down Button until "**ScrnSv**" is highlighted, then push the Enter Button to select.

**Step 3.)** Push the Up or Down Button until the desired option is highlighted, then push the Enter button.

<b><u>OPTION</u></b>	<b><u>DESCRIPTION</u></b>
<b>OFF</b>	Sleep Mode Disabled
<b>1 M</b>	1 Minute
<b>3 M</b>	3 Minutes
<b>5 M (DEFAULT)</b>	5 Minutes
<b>10 M</b>	10 Minutes

**Step 4.)** Push the Up and Down Buttons simultaneously to exit the Function Menu.

### 3.6.6 Performing a Built-In Test

The "Test" function allows the operator to perform tests against the internal hardware to ensure proper operation. It consists of multiple test steps, and a message is displayed at each step.

#### **To Perform a Built-In Test:**

- Step 1.)** Make sure the *RAID Xe* is fitted with fresh batteries.
- Step 2.)** Push the Up and Down Buttons simultaneously to access the Function Menu.
- Step 3.)** Push the Up or Down Button until "**Test**" is highlighted, then push the Enter Button to select.
- Step 4.)** Push the Up or Down Button to step through the tests until the final screen is displayed. The final screen will display "Done All Passed" if the test passed, or "Done [#] Failed" if it failed (where [#] is the number of failed tests). Note: if you continue to push the Up or Down button, testing will be repeated.
- Step 5.)** Push the Enter Button to exit testing.
- Step 6.)** Push the Up and Down Buttons simultaneously to exit the Function Menu.

### 3.6.7 Setting Factory Defaults

The “Deflt” function allows the operator to restore *RAID Xe* settings to the defaults set at the factory. These settings include the low power mode laser step (default = **3**) high power mode laser step (default = **10**), laser ID blink pattern (default = “**ID:OFF**”), the display brightness (default = “**AUTO**”), keypad configuration (default = 1: |Lr|, 2: Fire, 3: DH |), sleep mode timer (default = 5 M), and maintenance counter configuration (default = “**GasImp**”).

#### To Restore Factory Defaults:

- Step 1.)** Push the Up and Down Buttons simultaneously to access the Function Menu.
- Step 2.)** Push the Up or Down Button until “**Deflt**” is highlighted, then push the Enter Button to select.
- Step 3.)** Push the Up or Down button until “**Reset**” is highlighted. Alternatively, push the Up or Down button until “**NoRst**” is highlighted if you do NOT wish to set factory defaults.
- Step 4.)** Push the Enter Button to select.
- Step 5.)** Turn the Mode Selection Switch to the “OFF” position. The *RAID Xe* is now reset and restoration is now complete.

### 3.6.8 Displaying the Maintenance Counter and Setting Weapon Type for Maintenance Counter Accuracy

The "Maint" function displays the accumulated count of laser activations over the life of the **RAID Xe**. To get a count of laser activations during an operation, log the pre-operational count for later comparison post-operation. It also allows the operator to configure the Maintenance Counter to look for the correct weapon signature when counting shots. Doing this prior to operation provides for better counter accuracy.

#### To Display the Maintenance Counter and Optionally Set Weapon Type:

- Step 1.)** Push the Up and Down Buttons simultaneously to access the Function Menu.
- Step 2.)** Push the Up or Down Button until "**Maint**" is highlighted, then push the Enter Button to select. The current shot count displays.
- Step 3.)** If you wish to set the Weapon Type to ensure Maintenance Counter Accuracy, refer to the following steps. Otherwise, skip to Step 4.
  - Step 3a.)** Push the Up and Down Buttons until "**Config**" is highlighted, then push the Enter Button to select.
  - Step 3b.)** Push the Up and Down Buttons to highlight "**GasImp**" (Gas Impingement - DEFAULT) or "**Piston**" (Piston Driven), then push the Enter Button to Select.
- Step 4.)** Push the Up and Down Buttons simultaneously to exit the Function Menu.

### 3.6.9 Displaying the Event Log

The “Events” function displays up to three (3) events, categorized by their criticality from low to high as follows: “I” = Information, “W” = Warning, and “E” = Error. Warning and error events will cause a highlighted “!” to display briefly below the battery indicator. Refer to Section 4.7 for code definition.

#### **To Display the Event Log:**

**Step 1.)** Push the Up and Down Buttons simultaneously to access the Function Menu.

**Step 2.)** Push the Up or Down Button until “Events” is highlighted, then push the Enter Button to display the Event Log:

**Event 1:** The first event since Power On.

**Event 2:** The next event, or the first higher level event.

**Event 3:** The most recent highest level event.

**Step 3.)** Push any button to exit the Event Display and return to the Function Menu.

**Step 4.)** Push the Up and Down Buttons simultaneously to exit the Function Menu.

### **3.6.10 Displaying the About Screen**

The “About” function allows the operator to display unit information. The information is displayed on two screens. The first screen displays the software revision, hardware revision, and battery percentage level. The second screen includes the unit serial number and model configuration.

#### **To Display the About Screen:**

- Step 1.)** Push the Up and Down Buttons simultaneously to access the Function Menu. The first function menu option (i.e., “Bright”) appears on the display.
- Step 2.)** Push the Up or Down Button until “**About**” is highlighted, then push the Enter Button to select. The first system information screen displays.
- Step 3.)** Push the Up or Down Button once again to display the second page of information. This information includes the product serial number and the model (“Rd” for Red Laser or “Gr” for Green Laser).
- Step 4.)** Push the Enter Button to return to the Function Menu or the Up and Down Buttons simultaneously to exit the Function Menu.

### **3.7 BORESIGHT PROCEDURE (ESTABLISHING THEORETICAL ZERO WITH A LASER BORESIGHT KIT)**

The lasers are co-aligned at the factory and are all adjusted simultaneously. Follow your organization's procedures for boresighting. Whenever possible, follow with live fire to verify aiming accuracy.

#### **▲ WARNING ▲**

**When mounting the *RAID Xe* to a weapon or to a new rail position, it is necessary to properly boresight the *RAID Xe* to the weapon to ensure aiming accuracy.**

#### **■ CAUTION ■**

**The beam of the laser emitting from the *RAID Xe* indicates the area of round impact, provided the boresighting procedures have been properly followed. Be aware of the direction in which the weapon is pointed, as well as the direction of the intended target, prior to firing a round.**

#### **NOTE**

**When boresighting the *RAID Xe* to the target, it is recommended that only the low power Visible Laser be used.**

### **3.8 PRE-OPERATION CHECKLIST**

Prior to operation, perform the following pre-operational checks to ensure proper system operation.

#### **■ CAUTION ■**

**It is recommended that the battery be replaced and that activation procedures for the *RAID Xe* be conducted prior to operation to ensure proper operation prior to use (see Section 4.2).**

- Step 1.)** Make sure a fresh CR123 battery has been installed.
- Step 2.)** Note and record the maintenance count for comparison to the post-operational count as described in Section 3.6.8.
- Step 3.)** Set the Maintenance Counter to the correct weapon configuration as instructed in Section 3.6.8.
- Step 4.)** Remove the lens covers.
- Step 5.)** Mount the *RAID Xe* to the primary weapon and zero the weapon to the lasers as instructed in Section 3.7.



### **3.9 OPERATING THE RAID Xe**

To quickly fire the weapon, align to the target using the selected pointer laser and fire.

---

#### **NOTE**

---

**After 5 minutes of inactivity, the RAID Xe laser timer will deactivate the lasers. Pressing the FIRE Button will reactivate the laser.**

- Step 1.)** Make sure all pre-operational steps have been performed as described in Section 3.8.
- Step 2.)** Remove the lens/laser cover from the Laser Port (Aperture) and store under the device.
- Step 3.)** Verify that the weapon is level to the horizon.
- Step 4.)** Turn the Mode Selection Knob to the desired mode position. The selected mode displays on the OLED Screen along with a battery power indicator.
- Step 5.)** To activate or deactivate the selected laser, push the "Fire" button on the **RAID Xe** or, if applicable, the configured button on the Three Button Pressure Pad. To activate or deactivate an attached Surefire flashlight, regardless of the laser mode selected (as described in Section 2.4), press the flashlight button on the Three Button Pressure Pad (Optional Dual cable only).

- Step 6.)** To adjust laser brightness while any laser is active, push the Enter Button to enter the laser power adjustment mode then use the Up and Down buttons to adjust the pointer laser power output. When in a dual mode, the IR Pointer is adjusted first. After adjusting the pointer laser, push the Enter Button again to adjust the illuminator. Upon exiting power adjustment, laser powers are saved and will persist through power cycling.
- In high power laser modes the IR Pointer, IR Long Range Illuminator, and Visible Pointer support laser power steps 1-10, with step 10 being the highest. In low power modes the IR Pointer, IR Long Range Illuminator, and Visible Pointer support laser power steps 1-3, which is the calibrated low laser power range. The IR Room Illuminator supports steps 1-5 at any point, with 5 being the highest output.
- Step 7.)** Align the laser with the target. The system is now ready to operate.
- Step 8.)** Fire the weapon as instructed in its operator's manual.
- Step 9.)** When not operating the **RAID Xe**, place the Mode Selection Knob in the "0" (OFF) position and replace the lens/laser covers on the Laser Ports (Apertures).

---

## SECTION 4

### MAINTENANCE

---

#### 4.1 CARE OF THE *RAID Xe*

---

##### NOTE

---

**Do not use harsh abrasives or chemicals such as acetone to clean the *RAID Xe*. Clean only as instructed in Section 4.1.**

**Periodically inspect the Battery Compartment O-ring. If the Battery Compartment Cap O-ring becomes cut, nicked, or torn, notify unit armorer.**

Dismount the *RAID Xe* from the primary weapon and inspect the unit for dirt, rust, and corrosion. If the display or lenses are broken or cloudy, notify the unit armorer.

Make sure the Battery Compartment Cap and O-ring are tightly sealed and that the area is free of sand and dirt particles. If a Battery Compartment Cap O-ring becomes cut, nicked, or torn, notify unit armorer.

Dirt and other residue, like exposure to salt water, may impede the mechanical operation of the *RAID Xe*. Flush exterior with fresh water to remove any debris. Blow any residual dirt or dust free from the lenses, then wipe with a clean Lens Cloth, provided. Do not use the brush provided for cleaning optic glass and laser port (aperture) lenses. Using the brush, remove dirt and debris from the mounting rails and controls. This should be done on a regular basis.

After flushing and cleaning with fresh water to remove debris, if further lens cleaning is necessary, use the clean Lens Cloth provided with a small amount of Isopropyl (Rubbing) Alcohol.

Always keep the Lens Covers and Battery Cap fully installed when not in use to prevent entry of foreign debris, protect the port from corrosion, and prevent scratching of the lenses.

## 4.2 BATTERY REPLACEMENT

The **RAID Xe** operates on one (1) CR123 battery. When the battery is not correctly installed, the positive (“+”) post of the battery cannot make contact. Install as illustrated in Figure 4.2-1. Refer to Table 4.2-1 for total estimated runtime after installing a fresh CR123 battery.

**Table 4.2-1. RAID Xe Estimated Run Time  
(by Ambient Temperature)**

ESTIMATED REMAINING BATTERY LIFE	
TEMPERATURE	ESTIMATED REMAINING RUN TIME*
-20°C (-4°F)	<4 Hours**
-10°C (14°F)	<4 Hours**
0°C (32°F)	<4 Hours**
10°C (50°F)	<4 Hours**
20°C (68°F)	<4 Hours**
30°C (86°F)	<4 Hours**
40°C (104°F)	<4 Hours**
50°C (122°F)	<4 Hours**
60°C (140°F)	<4 Hours**

\*Tested with Surefire CR123 battery in Dual High Mode. Operator can expect longer operational run times when operating in other modes.

\*\*Estimated run time depending on operational use.

The Battery Indicator on the **RAID Xe** Display shows up to 4 bars, one bar for approximately each 20% of remaining battery life (see Table 4.2-2). If no bars appear in place of the indicator, the **RAID Xe** has less than 20% of battery life remaining.

**Table 4.2-2. RAID Xe Estimated Remaining Battery Life (by Ambient Temperature)**



ESTIMATED REMAINING BATTERY LIFE	
TEMPERATURE	ESTIMATED REMAINING RUN TIME FROM WHEN YOU FIRST SAW THE LOW BATTERY INDICATOR *
-20°C (-4°F)	1 Hour
-10°C (14°F)	30 Minutes
0°C (32°F)	20 Minutes
10°C (50°F)	12 Minutes
20°C (68°F)	6 Minutes
30°C (86°F)	6 Minutes
40°C (104°F)	6 Minutes
50°C (122°F)	6 Minutes
60°C (140°F)	6 Minutes

\* Tested with Surefire CR123 battery in Dual High Mode. Operator can expect longer operational run times when operating in other modes.

When the low battery indicator appears on the display, all active lasers will briefly flash five (5) fast blinks. This blink sequence will also occur if a low battery condition exists when activating a laser.

When lasers flash to indicate a low battery, remaining battery life will depend on operational temperature (see Tables 4.2-1 and 4.2-2). When this occurs, performance of the **RAID Xe** will be degraded in accordance with Table 4.2-2. Replace the used CR123 size battery when the Battery Indicator becomes low.

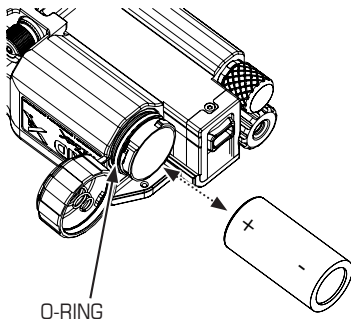
**Table 4.2-3. RAID Xe Key Display Indicators**

INDICATOR	DESCRIPTION
	Low Battery (Less than 20% Remaining)
	Full Battery

REMOVE BATTERY CAP BY TURNING CCW 1/4 TURN AND REMOVING CAP.

INSTALL ONE (1) FRESH CR123 BATTERY (SOLD SEPARATELY) PRIOR TO OPERATION, "+" SIDE FIRST.

INSPECT BATTERY COMPARTMENT O-RING SEAL FOR DAMAGE OR WEAR. REPLACE IF NECESSARY, LUBRICATING THE O-RING WITH A SILICONE GREASE PRIOR TO INSTALLATION.



**Figure 4.2-1 Replacing the Battery in the RAID Xe**



## 4.3 INSPECTING AND REPLACING O-RINGS

### ■ CAUTION ■

**Failure to maintain the O-ring may affect product performance.**

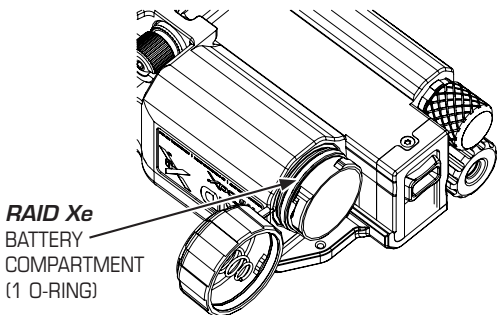
The Battery Compartment of the **RAID Xe** contains one (1) Buna O-ring that prevents dirt and water entry to the Battery Compartment.

Age and temperature can wear Buna rubber, so O-rings should be inspected periodically to maintain proper operation of the system. O-rings are highly pliable and stretchable and can be overstretched in the process of inspection. For this reason, it is strongly advised that they be replaced whenever they are removed to ensure proper sealing of the compartment.

O-ring replacements are available through Wilcox and should be purchased in advance of need to ensure continued service.

- Step 1.)** Gently brush any debris away from the O-ring with the provided cleaning brush.
- Step 2.)** Inspect the O-ring for cracks, pinches, hardness, dryness, or tackiness of feel. If the O-ring exhibits any of these characteristics, replace it.
- Step 3a.)** If the **RAID Xe** O-ring does not need replacement, but requires lubrication, lubricate the exterior surface of the O-ring without removing it with a small amount of Silicone Grease.

- Step 3b.)** If replacement is required, gently remove the O-ring using a pick tool. Gently lubricate the **RAID Xe** O-ring on both sides with the thumb and index finger using Silicone Grease. Using the pick tool, gently replace the lubricated O-ring, using caution not to overstretch or damage.



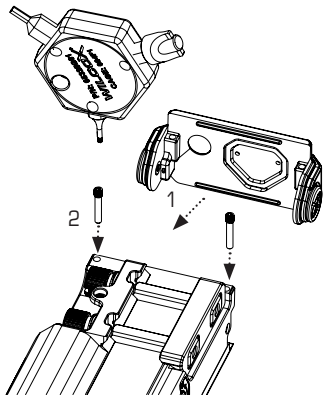
**Figure 4.3-1 Inspecting and Replacing O-Ring**

## 4.4 ATTACHING AND DETACHING THE *RAID Xe* LASER SAFETY COVERS

The *RAID Xe* is provided with two Laser Safety Cover options for prevention of lens damage and to prevent accidental exposure to active lasers.

### To Attach the Laser Safety Hood:

- Step 1.)** Slide the Laser Safety Hood over the end of the *RAID Xe* case so that the pin holes align with the holes in the case.
- Step 2.)** Insert the pins into the mounting holes in the case and slide through the holes of the soft cover. Thread the screws on CW using the Xe Utility Tool or .050" Hex Key. DO NOT overtighten.



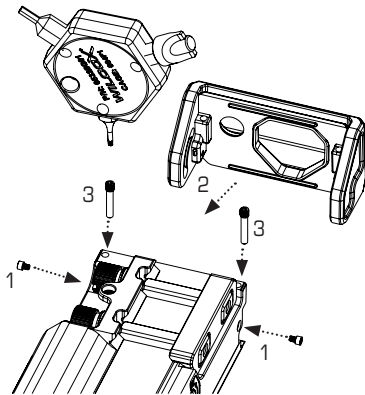
**Figure 4.4-1. Attaching the *RAID Xe* Laser Safety Hood**

**To Detach the Laser Safety Hood:**

Follow instructions for attaching in reverse.

**To Attach the Laser Safety Visor:**

- Step 1.)** Insert the Side Pivot Posts and thread CW using the Xe Utility Tool or .050" Hex Key. DO NOT overtighten.
- Step 2.)** Slide the Laser Safety Visor over the end of the **RAID Xe** case so that the pin holes align with the holes in the case.
- Step 3.)** Insert the pins into the mounting holes in the case and slide through the holes of the soft cover. Thread the screws on CW using the Xe Utility Tool or .050" Hex Key. DO NOT overtighten.



**Figure 4.4-2. Attaching the RAID Xe Laser Safety Visor**

### **To Detach the Laser Safety Visor:**

Follow instructions for attaching in reverse.

## **4.5 STORAGE**

Make sure the cleaning instructions in Section 4.1 have been followed. When the **RAID Xe** is dismantled for storage, place the Mode Selection Knob in the "OFF" position. Resecure the laser cover to the **RAID Xe** lens port (aperture) to prevent dust and dirt entry. Remove battery from the **RAID Xe** and retain.

### **■ CAUTION ■**

**Do not store the *RAID Xe* with the battery installed.**

## **4.6 SHIPPING**

Prior to shipping the **RAID Xe**, follow cleaning and storage instructions as described in Sections 4.1 and 4.5. Package all components securely in a suitable shipping container, maintaining adequate separation between components.

## 4.7 TROUBLESHOOTING

Use the Event Log function on the Function Menu to determine the cause of system events. The Event Log displays up to 3 events:

- **Event 1:** is the first event since the last power up.
- **Event 2:** is the next event or the first highest level event.
- **Event 3:** is the most recent event of the highest level.

### Event Levels

- Levels are an indication of importance.
- Levels include: **Information (I)**, **Warning (W)**, and **Error (E)**.
- When a Warning or Error event occurs, the Event Flag, '!', is displayed above the battery icon.

Table 4.7-1 identifies the codes, causes and solutions of these events. If an event code should display and persists after attempting to perform the solutions listed in the table, please contact Wilcox Customer Service for assistance at 603-431-1331.

**Table 4.7-1. System Events**

EVENT LEVEL	EVENT CODE	DESCRIPTION	SOLUTION
I	71	Update patch applied. This may occur on firmware updating to initialize changes to persistent storage.	No action required.
W	72	Low battery detected during storage of a configuration change. The change was NOT stored in persistent memory. However, the attempted change is in active memory and the unit can be operated using the changed value until the next power cycle. This event displays "LO-BAT" at the bottom of the display.	1. Use unit with changes not saved. 2. Replace battery and try again (refer to Section 4.2).
E	75	Setting defaults failed. This may occur after a "LO-BAT" event.	Install a fresh battery and try again (refer to Section 4.2).

E = Error, W = Warning, I = Information

---

## **APPENDIX A**

### **WARRANTY STATEMENT**

---

#### **A.1 STANDARD LIMITED WARRANTY**

Wilcox Industries Corp. ("WX") offers a limited warranty ("Limited Warranty") that its products will be free from defects in material and workmanship under proper usage for one (1) year from the date of original shipment from WX ("Warranty Period") if purchased through an authorized sale, provided that, the product and purchasing documents are returned to WX (at user's expense) and WX will have the option (in its sole discretion) to exchange or recondition the product (subject to WX's examination and confirmation that the product is defective), and return the product via preapproved carrier at user's expense. This Limited Warranty is void if the date of manufacture which is laser engraved on the product is defaced, modified, or altered. This Limited Warranty is only for products purchased directly from WX or an authorized reseller. Items purchased via ecommerce such as Ebay, Craigslist, Amazon, or any other online marketplaces are not eligible for the Limited Warranty.

The Limited Warranty does not include damage or defects arising from improper use, maintenance, repairs, installation or storage, abuse, misapplication, vandalism, negligence, neglect, normal wear and tear, or any other circumstances over which WX has no control.

WX MAKES NO OTHER WARRANTIES, EXPRESS OR IMPLIED. WX SPECIFICALLY DISCLAIMS ALL OTHER WARRANTIES, EXPRESS OR IMPLIED, INCLUDING BUT NOT LIMITED TO, THE WARRANTIES OF MERCHANTABILITY AND/OR FITNESS FOR A PARTICULAR PURPOSE.



THE LIMITED WARRANTY IS YOUR SOLE AND EXCLUSIVE REMEDY FOR WARRANTY COVERAGE, WX CONDUCT, OR FOR ANY OTHER CLAIM OR CAUSE OF ACTION AGAINST WX. WX SHALL NOT BE RESPONSIBLE FOR ANY DAMAGES WHETHER DIRECT, INCIDENTAL, CONSEQUENTIAL OR OTHERWISE, INCLUDING, BUT NOT LIMITED TO, LOST PROFITS, LABOR CHARGES, REPAIRING OTHER PRODUCTS, REPLACEMENTS, OR ANY DELAYS.

IN ADDITION, TO THE FULLEST EXTENT PERMISSIBLE BY LAW, WX SHALL NOT BE LIABLE FOR ANY INJURY OR DAMAGE TO PERSONS OR PROPERTY OF ANY KIND. IN NO EVENT SHALL WX BE LIABLE FOR DIRECT, SPECIAL, INDIRECT, PUNITIVE, INCIDENTAL OR CONSEQUENTIAL DAMAGES, INCLUDING, BUT NOT LIMITED TO, LOSS OF PROFITS, FUTURE REVENUE, DATA, OR ANY OTHER LOSS, REGARDLESS OF WHETHER A CLAIM OR ACTION IS ASSERTED IN CONTRACT OR TORT, WHETHER OR NOT THE POSSIBILITY OF SUCH DAMAGES HAS BEEN DISCLOSED IN ADVANCE OR COULD HAVE BEEN REASONABLY FORESEEN.

NOTWITHSTANDING ANY OTHER AGREEMENT OR UNDERSTANDING BETWEEN THE PARTIES, THE PARTIES AGREE THAT ALL LIABILITY WITH RESPECT TO A CLAIM AGAINST WX IN CONNECTION WITH OR RELATED TO ANY PRODUCT PROVIDED BY WX SHALL BE LIMITED IN DURATION TO THE WARRANTY PERIOD AND SOLELY TO DIRECT DAMAGES, AND MAY BE SATISFIED BY REPAIR OR REPLACEMENT OF NONCONFORMING PRODUCT (AS DETERMINED BY WX IN ITS SOLE AND ABSOLUTE DISCRETION), AND IN NO EVENT SHALL THE AGGREGATE RECOVERY OF ANY KIND AGAINST WX EXCEED THE LESSER OF TWENTY THOUSAND DOLLARS (\$20,000 USD) OR THE PURCHASE PRICE OF THE PRODUCT.

## **A.2 WARRANTY CLAIM AND SERVICE INFORMATION**

For warranty claim or service work, WX must be contacted in the United States at +1 603-431-1331 to assign a Return Merchandise Authorization (RMA)/Service Call Number (SC) prior to return shipment.

After an RMA/SC number is provided, WX will accept a package at the address below, clearly marked with the number assigned as follows:

**Wilcox Industries Corp.**  
**RMA/SC # \_\_\_\_\_**  
**One Wilcox Way**  
**Newington, NH 03801 USA**

The **RAID Xe** must be securely packaged, accompanied by purchasing information, a letter including sender's name, address, daytime phone number, date of manufacture, lot number, and a description of the problem or work to be performed.

---

## APPENDIX B

### ABBREVIATIONS

---

#### B.1 ABBREVIATIONS

<b>CCW</b>	Counterclockwise
<b>CW</b>	Clockwise
<b>in<sup>3</sup></b>	Cubic Inches
<b>in-lb</b>	Inch-Pound
<b>IR</b>	Infrared
<b>ITAR</b>	International Traffic in Arms Regulations
<b>mm</b>	Millimeter
<b>mrad</b>	Milliradian
<b>NFOV</b>	Near Field of View
<b>nm</b>	Nanometer
<b>NVG</b>	Night Vision Goggle
<b>OLED</b>	Organic Light Emitting Diode
<b>oz</b>	Ounce(s)
<b>RAID Xe</b>	Ruggedized Aiming/Illumination Device - Enhanced
<b>WFOV</b>	Wide Field of View

---

## APPENDIX C

### SPARE AND OPTIONAL PARTS

---

#### C.1 SPARE AND OPTIONAL PARTS LISTS

To order replacement and optional parts, contact the Wilcox sales department at +1 603-431-1331. Please specify your product color when ordering.

---

#### NOTE

---

Wilcox supplies “Non-Berry”-compliant tactical pouches unless specified prior to ordering.

Note the repair type specified for the following replacement parts is identified as follows:

- **Field** – Can be changed out at the field level.
- **Armorer** – Can be changed out by the unit armorer.
- **Factory** – A change that occurs at the factory level only.

**Table C-1. Spare Parts List**

#	PART NO	DESCRIPTION	REPAIR TYPE	REFERENCE
C.1.1	65334G02	BATTERY CAP ASSEMBLY	FIELD	Page 12
C.1.2	65334G04	BATTERY CAP TETHER LINE WITH CRIMP SLEEVES - BLACK	ARMORER	Page 53
C.1.3	F1424	BRUSH, ALL PURPOSE, DOUBLE END	FIELD	Page 13
C.1.4	F1968	MICROFIBER LENS CLEANING CLOTH	FIELD	Page 13
C.1.5*	F2509	POUCH - 7 X 5 X 2.25 COYOTE NON-BERRY COMPLIANT	FIELD	Page 9
C.1.6	F2481	BLUE LOCKOUT SCREW	FIELD	Page 11
C.1.7	F3014	BATTERY COMPARTMENT O-RING	FIELD	Page 53
C.1.8	68401G01	WILCOX ERGOCTO XE (3) BUTTON PRESSURE PAD - SINGLE 12" CABLE	FIELD	Page 9
C.1.9	65341P25	CAP - CONNECTOR - FISCHER	FIELD	Page 12
C.1.10	F3358	WASHER FLAT	FIELD	
C.1.11	65341G02	ASSEMBLY COVER / VISOR / LASER SAFETY	FIELD	Page 9
C.1.12	65341G03	ASSEMBLY COVER / LASER SAFETY/RUBBER	FIELD	Page 9
C.1.13	42855P16	THREADED STUD FOR LASER SAFETY COVERS (2)	FIELD	Page 56
C.1.14	42855P17	THREADED STUD - STOP FOR LASER SAFETY VISOR	FIELD	Page 57
C.1.15	65325G01	XE UTILITY TOOL	FIELD	Page 9
C.1.16	68405G01	ERGOCTO XE - PICATINNY RAIL ADAPTER	FIELD	Page 9

\*For non-standard pouches, please specify when ordering.

**Table C-2. Optional Parts List**

PART NO	DESCRIPTION
68401G03	WILCOX ERGOCTO XE (3) BUTTON PRESSURE PAD - DUAL (SUREFIRE FLASHLIGHT INTERFACE)

*“Our Customer’s Life Depends on It”™*



Manufactured by:

**WILCOX®**

Wilcox Industries Corp.  
One Wilcox Way  
Newington, NH 03801 USA

Phone: +1 603-431-1331

Fax: +1 603-431-1221



**RAID Xe HP**



**RAID Xe LP**

Visit us at: [WWW.WILCOXIND.COM](http://WWW.WILCOXIND.COM)

For troubleshooting service questions,  
contact Wilcox between 8am and 5pm EST.